

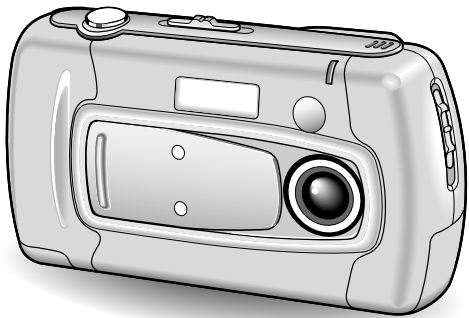

SERVICE MANUAL

Color Digital Camera



VPC-X360E

(Product Code : 126 251 01)
(U.K.)

VPC-X360EX

(Product Code : 126 251 02)
(Europe)
(PAL General)

VPC-X360

(Product Code : 126 251 03)
(U.S.A.)
(Canada)

Contents

1. OUTLINE OF CIRCUIT DESCRIPTION	2
2. DISASSEMBLY	12
3. ELECTRICAL ADJUSTMENT	15
4. TROUBLESHOOTING GUIDE	20
5. PARTS LIST	21
CABINET AND CHASSIS PARTS 1	21
CABINET AND CHASSIS PARTS 2	22
ELECTRICAL PARTS	23
ACCESSORIES	28
PACKING MATERIALS	28
CIRCUIT DIAGRAM (Refer to the separate volume)	

PRODUCT SAFETY NOTICE

The components designated by a symbol (\triangle) in this schematic diagram designates components whose value are of special significance to product safety. Should any component designated by a symbol need to be replaced, use only the part designated in the Parts List. Do not deviate from the resistance, wattage, and voltage ratings shown.

CAUTION : Danger of explosion if battery is incorrectly replaced.

Replace only with the same or equivalent type recommended by the manufacturer.
Discard used batteries according to the manufacturer's instructions.

NOTE : 1. Parts order must contain model number, part number, and description.
2. Substitute parts may be supplied as the service parts.
3. N. S. P. : Not available as service parts.

Design and specification are subject to change without notice.

1. OUTLINE OF CIRCUIT DESCRIPTION

1-1. CA-1 CIRCUIT DESCRIPTION

1. IC Configuration

IC903 (ICX204AK)	CCD imager
IC902 (74VHC04MTC)	H driver
IC904 (CXD1267AN)	V driver
IC905 (AD9802)	CDS/AGC, A/D converter

2. IC903 (CCD)

[Structure]

Interline type CCD image sensor

Optical size	1/3 inch format
Effective pixels	1034 (H) × 779 (V)
Pixels in total	1077 (H) × 788 (V)
Chip size	5.80 mm (H) × 4.92 mm (V)
Unit cell size	4.65 μm (H) × 4.65 μm (H)
Optical black	
Horizontal (H) direction:	Front 3 pixels, Rear 40 pixels
Vertical (V) direction:	Front 7 pixels, Rear 2 pixels
Dummy bit number	Horizontal : 29 Vertical : 1

[Features]

- Independent storage and retrieval for each pixel
- Square pixel unit cell
- XGA compatible
- R, G, B primary color mosaic filter
- Continuous variable speed electronic shutter function

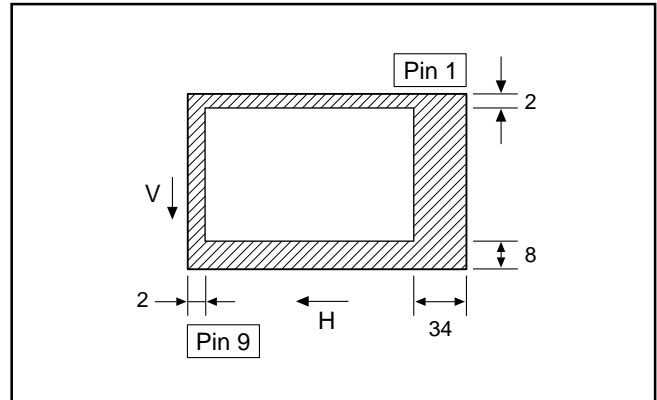

Fig. 1-1. Optical Black Location (Top View)

Pin No.	Symbol	Pin Description	Waveform	Voltage
1	V ₃	Vertical shift register gate clock		-7.5 V, 0 V
2	V _{2B}	Vertical shift register gate clock		-7.5 V, 0 V, 15 V
3	V ₁	Vertical shift register gate clock		-7.5 V, 0 V
4	V _{2A}	Vertical shift register gate clock		-7.5 V, 0 V, 15 V
5, 6, 7, 10	GND	GND		
8	OS	Image output		
9	OD	Output transistor drain		15 V
11	SUB	Board clock		Amplitude 22.5 V Ex. 6 V (Bias level is different from every CCD)
12	O _{SUB}	Board bias	DC	(Different from every CCD) Ex. 6V
13	PL	Protection transistor bias	DC	-7.5 V
14	RS	Reset transistor gate clock		Amplitude 3.5 V Ex. 5 V, 10 V (Different from every CCD)
15	H1	Horizontal shift register transfer clock		0 V, 3.5 V
16	H2	Horizontal shift register transfer clock		0 V, 3.5 V

Table 1-1. CCD Pin Description

----When sensor read-out

3. IC902 (H Driver) and IC904 (V Driver)

An H driver (IC902) and V driver (IC904) are necessary in order to generate the clocks (vertical transfer clock, horizontal transfer clock and electronic shutter clock) which driver the CCD.

IC902 is an inverter IC which drives the horizontal CCDs (H1 and H2). In addition the XV1-XV4 signals which are output from Pins (166), (167), (169) and (171) of IC102 are the vertical transfer clocks, and the XSG1 and XSG2 signals which is output from Pins (168) and (170) of IC102 is superimposed onto XV1 and XV3 at IC904 in order to generate a ternary pulse. In addition, the XSUB signal which is output from Pin (165) of IC102 is used as the sweep pulse for the electronic shutter, and the RG signal which is output from Pin (159) of IC102 is the reset gate clock.

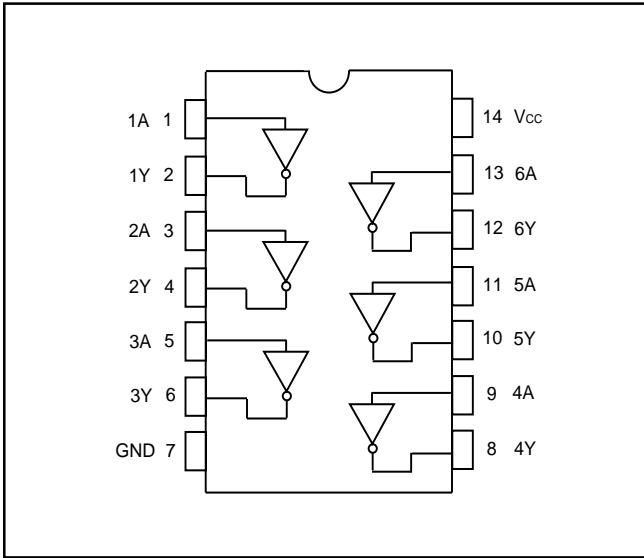

Fig. 1-2. IC902 Block Diagram

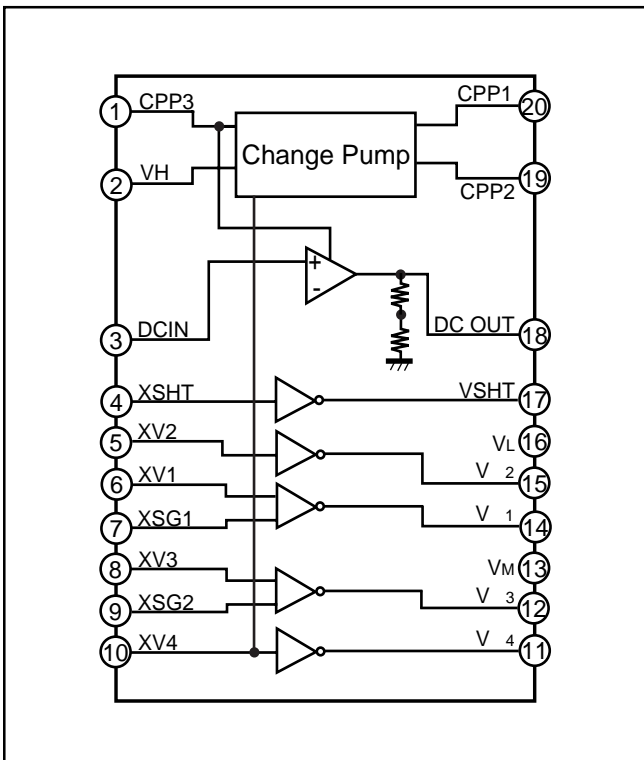

Fig. 1-3. IC904 Block Diagram

4. IC905 (CDS, AGC Circuit and A/D converter)

The video signal which is output from the CCD is input to Pins (26) and (27) of IC905. There are S/H blocks inside IC905 generated from the XSHP and XSHD pulses, and it is here that CDS (correlated double sampling) is carried out.

After passing through the CDS circuit, the signal passes through the AGC amplifier. It is A/C converted internally into a 10-bit signal, and is then input to IC102 of the CA2 circuit board. The gain of the AGC amplifier is controlled by the voltage at pin (29) which is output from IC102 of the CA2 circuit board and smoothed by the PWM.

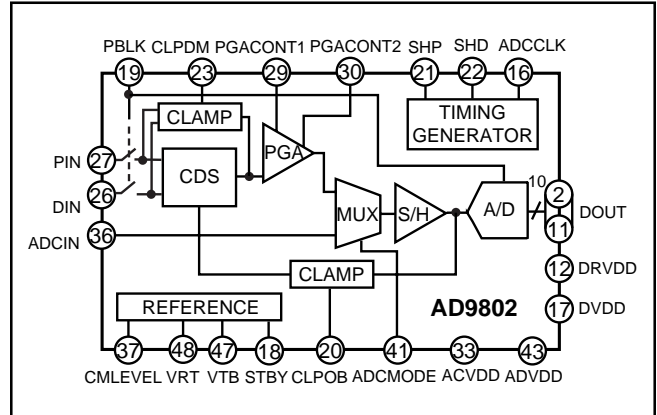

Fig. 1-4. IC905 Block Diagram

5. Transfer of Electric Charge by the Horizontal CCD

The transfer system for the horizontal CCD employs a 2-phase drive method.

The electric charges sent to the final stage of the horizontal CCD are transferred to the floating diffusion, as shown in Fig. 1-5. RG is turned on by the timing in (1), and the floating diffusion is charged to the potential of PD. The RG is turned off by the timing in (2). In this condition, the floating diffusion is floated at high impedance. The H1 potential becomes shallow by the timing in (3), and the electric charge now moves to the floating diffusion.

Here, the electric charges are converted into voltages at the rate of $V = Q/C$ by the equivalent capacitance C of the floating diffusion. RG is then turned on again by the timing in (1) when the H1 potential becomes deep.

Thus, the potential of the floating diffusion changes in proportion to the quantity of transferred electric charge, and becomes CCD output after being received by the source follower. The equivalent circuit for the output circuit is shown in Fig. 1-6.

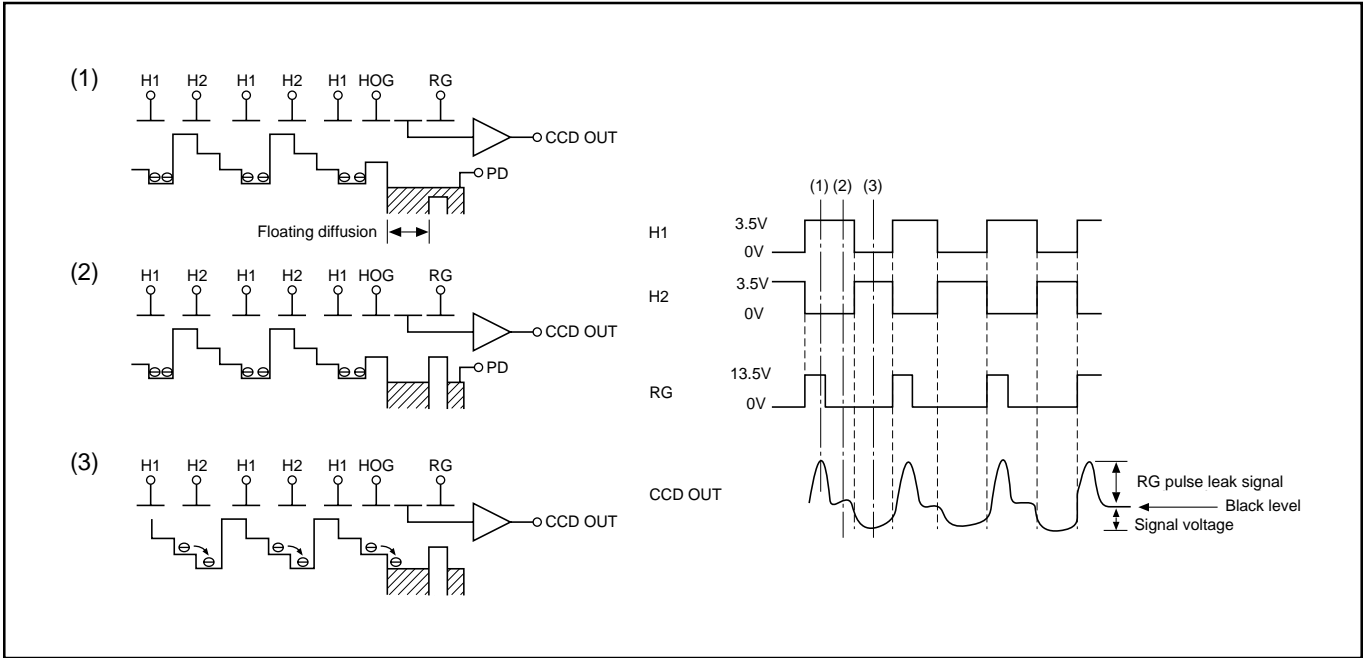

Fig. 1-5. Horizontal Transfer of CCD Imager and Extraction of Signal Voltage

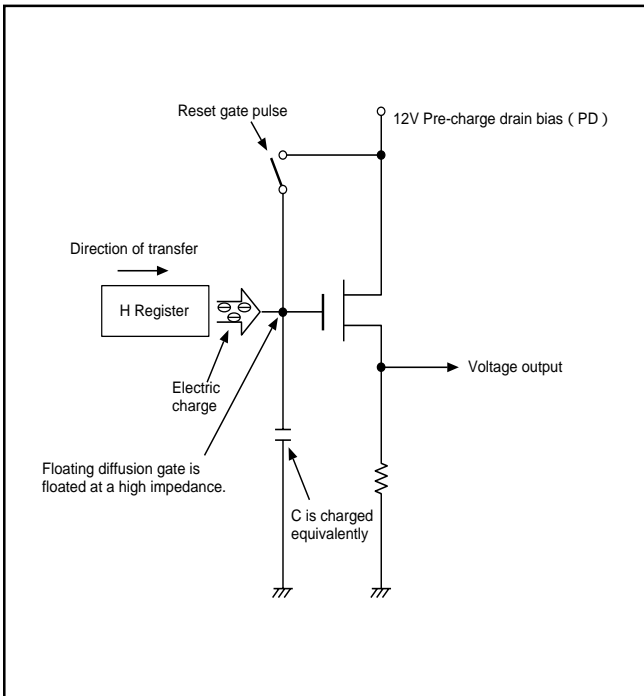

Fig. 1-6. Theory of Signal Extraction Operation

1-2. CA2 CIRCUIT DESCRIPTION

1. Circuit Description

1-1. Scanning converter (Interlace converter)

This circuit uses the function of a 64-Mbit SDRAMs to convert the non-interlaced signal which is output from the CCD into an interlaced signal for the video monitor.

1-2. Camera signal processor

This comprises circuits such as the digital clamp circuit, white balance circuit, circuit, color signal generation circuit, matrix circuit and horizontal aperture circuit.

1. Digital clamp circuit

The optical black section of the CCD extracts 16-pixel averaged values from the subsequent data to make the black level of the CCD output data uniform for each line. The 16-pixel averaged value for each line is taken as the sum of the value for the previous line multiplied by the coefficient k and the value for the current line multiplied by the coefficient $1-k$.

2. White balance circuit

This circuit controls the white balance by using the AWB judgement value computed by the CPU to control the gain for each R, G and B pixel based on the CCD data which has been read.

3. circuit

This circuit performs (gamma) correction in order to maintain a linear relationship between the light input to the camera and the light output from the picture screen.

4. Color generation circuit

This circuit converts the CCD data into RGB signals.

5. Matrix circuit

This circuit generates the Y signals, R-Y signals and B-Y signals from the RGB signals.

6. Horizontal aperture circuit

This circuit is used generate the aperture signal.

1-3. SDRAM controller

This circuit outputs address, RAS, CAS and AS data for controlling the SDRAM. It also refreshes the SDRAM.

1-4. PIO

The expansion parallel port can be used for functions such as stroboscope control and LCD driver control.

1-5. SIO (Serial control)

This is the interface for the 8-bit microprocessor.

1-6. TG, SG block

This is the timing generation circuit which generates the clocks (vertical transfer clock and electronic shutter clock) which drive the CCD.

1-7. 8-bit D/A circuit (Audio)

This circuit converts the audio signals (analog signals) from the microphone to 8-bit digital signals.

1-8. 8-bit A/D circuit (Audio)

The audio signals which were converted to digital form by the 8-bit A/D circuit are temporarily to a sound buffer and then recorded in the SSFDC card. During playback, the 8-bit D/A circuit converts these signals into analog audio signals.

1-9. Sound buffer

Audio memory

1-10. LCD driver

The Y/C signals which are input to the LCD driver are converted to RGB signals, and the timing signal which is necessary for LCD monitor display and the RGB signals are then supplied to the LCD monitor.

1-11. LCD monitor

This is the image display device which displays the image signals supplied from the LCD driver.

1-12. UART

This circuit is used for transmitting serial data to a PC. The interface is RS-232C-compatible.

1-13. SSFDC control

This reads data from the SSFDC card and stores it in SDRAM, and writes out the image data stored in SDRAM. In addition, error correction is carried out when the data is read.

1-14. MJPEG compression

Still and continuous frame data is converted to JPEG format, and movie images are compressed and expanded in MJPEG format.

2. Outline of Operation

When the shutter opens, the reset signals, TEST0, TEST1 and the serial signals ("take a picture" commands) from the 8-bit microprocessor are input and record operation starts. When the TG drives the CCD, picture data passes through the A/D and is then input to the ASIC as 10-bit data. This data then passes through the DCLP, AWB, shutter and circuit, after which it is input to the SDRAM. The AWB, shutter, , and AGC value are computed from this data, and two exposures are made to obtain the optimum picture. The data which has already been stored in the SDRAM is read by the CPU and color generation is carried out. Each pixel is interpolated from the surrounding data as being either R, G or B primary color data to produce R, G and B data. At this time, correction of the lens distortion which is a characteristic of wide-angle lenses is carried out. Aperture correction is carried out, and in case of still picture the data is then compressed by the JPEG method and in case of picture it is compressed by MJPEG method and is written to SSFDC card. When the data is to be output to an external device, it is read JPEG picture data from the SSFDC card and output to PC via the UART.

3. LCD Block

During EE, gamma conversion is carried out for the 10-bit RGB data which is input from the A/D conversion block of the CCD to the ASIC in order that the revised can be displayed on the video. The YUV of 640 x 480 is then transferred to the SVRAM.

The data which has accumulated in the SDRAM is after D/A conversion is carried out by SDRAM control circuit inside the ASIC, makes Y/C signal, the data is sent to the LCD panel and displayed.

If the shutter button is pressed in this condition, the 10-bit data which is output from the A/D conversion block of the CCD is sent to the SDRAM (DMA transfer), and is displayed on the LCD as a freeze-frame image.

During playback, the JPEG image data which has accumulated in the SSFDC card is converted to RGB signals. In the same way as for EE, the data is then sent to the SDRAM, after which D/A conversion is carried out inside the ASIC, and then the data is sent to the LCD panel and displayed.

The LCD driver is converted Y/C signals to RGB signals from ASIC, and these RGB signals and the control signal which is output by the LCD driver are used to drive the LCD panel. The RGB signals are 1H transposed so that no DC component is present in the LCD element, and the two horizontal shift register clocks drive the horizontal shift registers inside the LCD panel so that the 1H transposed RGB signals are applied to the LCD panel.

Because the LCD closes more as the difference in potential between the VCOM (common polar voltage: fixed at DC) and the R, G and B signals becomes greater, the display becomes darker; if the difference in potential is smaller, the element opens and the LCD become brighter. In addition, the brightness and contrast settings for the LCD can be varied by means of the serial data from the ASIC.

1-3. PW1 POWER CIRCUIT DESCRIPTION

1. Outline

This is the main power circuit, and is comprised of the following blocks.

Switching controller (IC501)

Digital and analog system and LCD 5.0 V system power output (L5010, Q5002, D5013, C5061)

Digital 3.3 V system power supply (L5017, Q5009, D5007, C5062)

Analog and LCD system power supply (Q5007, T5001)

Backlight power supply output (L5005, Q5008, D5014, C5005)

2. Switching Controller (IC501)

This is the basic circuit which is necessary for controlling the power supply for a PWM-type switching regulator, and is provided with four built-in channels, only CH1 (digital 3.3 V), CH2 (5 V system), CH3 (analog and LCD system) and CH4 (backlight system) are used. Feedback from 3.3 V (D) (CH1), 5.0 V (D) (CH2), +15.0 V (A), +12.4 V (L) (CH3) and 5.8 V (L) (CH4) power supply outputs are received, and the PWM duty is varied so that each one is maintained at the correct voltage setting level.

2-1. Short-circuit protection circuit

If output is short-circuited for the length of time determined by the condenser which is connected to Pin (17) of IC501, all output is turned off. The control signal (P ON, P(A) ON and LCD ON) are recontrolled to restore output.

3. Digital 3.3 V Power Output

3.3 V (D) is output. Feedback for the 3.3 V (D) is provided to the switching controller (Pins (1) of IC501) so that PWM control can be carried out.

4. 5 V System Power Output

5 V (D), 5.1 V (A) and 5 V (L) are output. Feedback for the 5 V (D) is provided to the switching controller (Pin (12) of IC501) so that PWM control can be carried out.

5. Analog and LCD System Power Output

15.0 V (A), -7.5 V (A), 12.4 V (L) and 15 V (L) are output. Feedback for the 15.0 V (A) with view mode and 12.4 V (L) with play mode is provided to the switching controller (Pin (25) of IC501) so that PWM control can be carried out.

6. Backlight Power Supply output

5.8 V (L) is output. Feedback is sent to pins (36) of the switching controller (IC501) for PWM control to be carried out.

1-4. PW1 STROBE CIRCUIT DESCRIPTION

1. Charging Circuit

When UNREG power is supplied to the charge circuit and the CHG signal becomes High (3.3 V), the charging circuit starts operating and the main electrolytic capacitor is charged with high-voltage direct current.

However, when the CHG signal is Low (0 V), the charging circuit does not operate.

1-1. Power switch

When the CHG signal switches to Hi, Q5406 turns ON and the charging circuit starts operating.

1-2. Power supply filter

L5401 and C5401 constitute the power supply filter. They smooth out ripples in the current which accompany the switching of the oscillation transformer.

1-3. Oscillation circuit

This circuit generates an AC voltage (pulse) in order to increase the UNREG power supply voltage when drops in current occur. This circuit generates a drive pulse with a frequency of approximately 50-100 kHz. Because self-excited light emission is used, the oscillation frequency changes according to the drive conditions.

1-4. Oscillation transformer

The low-voltage alternating current which is generated by the oscillation control circuit is converted to a high-voltage alternating current by the oscillation transformer.

1-5. Rectifier circuit

The high-voltage alternating current which is generated at the secondary side of T5401 is rectified to produce a high-voltage direct current and is accumulated at electrolytic capacitor C5412 on the main circuit board.

1-6. Voltage monitoring circuit

This circuit is used to maintain the voltage accumulated at C5412 at a constant level.

After the charging voltage is divided and converted to a lower voltage by R5417 and R5419, it is output to the SY1 circuit board as the monitoring voltage VMONIT. When this VMONIT voltage reaches a specified level at the SY1 circuit board, the CHG signal is switched to Low and charging is interrupted.

2. Light Emission Circuit

When RDY and TRIG signals are input from the ASIC expansion port, the stroboscope emits light.

2-1. Emission control circuit

When the RDY signal is input to the emission control circuit, Q5409 switches on and preparation is made to let current flow to the light emitting element. Moreover, when a STOP signal is input, the stroboscope stops emitting light.

2-2. Trigger circuit

When a TRIG signal is input to the trigger circuit, D5405 switches on, a high-voltage pulse of several kilovolts is generated inside the trigger circuit, and this pulse is then applied to the light emitting part.

2-3. Light emitting element

When the high-voltage pulse from the trigger circuit is applied to the light emitting part, current flows to the light emitting element and light is emitted.

Beware of electric shocks.

1-5. SY1 CIRCUIT DESCRIPTION

1. Configuration and Functions

For the overall configuration of the SY1 circuit board, refer to the block diagram. The configuration of the SY1 circuit board centers around a 8-bit microprocessor (IC301).

The 8-bit microprocessor handles the following functions.

1. Operation key input, 2. Mode LCD display, 3. Clock control, 4. Power ON/OFF, 5. Strobe charge control

Pin	Signal	I/O	Outline
1	CHG VOL	I	Strobe charge voltage input (analog input)
2	NOT USED	-	-
3~7	SCAN IN 0~4	I	Key matrix input
8	AVDD	-	A/D converter analog power terminal
9	AVREF	I	A/D converter standard voltage input terminal
10	STBY (R) LED	O	Standby LED (red) $\overline{\text{ON/OFF}}$ signal L : LED light
11	STBY (G) LED	O	Standby LED (green) $\overline{\text{ON/OFF}}$ signal L : LED light
12	VSS	-	GND
13	SELF LED (R)	O	Self-timer LED (red) $\overline{\text{ON/OFF}}$ signal L : LED light
14~19	NOT USED	-	-
20	AVREF $\overline{\text{ON}}$	O	A/D standard power $\overline{\text{ON/OFF}}$ signal L : ON
21	NOT USED	-	-
22	CHG ON	O	Flash charge $\overline{\text{ON/OFF}}$ signal H : ON
23~30	NOT USED	-	-
31	VSS	-	GND
32~69	NOT USED	-	-
70	P (A) ON	O	DC/DC converter (analog) $\overline{\text{ON/OFF}}$ signal H : ON
71	P ON	O	DC/DC converter (digital) $\overline{\text{ON/OFF}}$ signal H : ON
72	DIN CONNECT	I	DIN jack connect detection signal L : Connection
73	NOT USED	-	-
74	AV JACK	I	AV output cable connection detection signal L : Connection
75	SI	I	Serial communication data input (\leftarrow ASIC)
76	SO	O	Serial communication data output (\rightarrow ASIC)
77	SCK	O	Serial communication clock output (\rightarrow ASIC)
78	IC	-	Connect to Vss
79	XOUT	O	Main clock oscillation terminal (4 MHz)
80	XIN	I	Main clock oscillation terminal
81	VDD	-	Power supply terminal
82	XCIN	I	Sub clock oscillation terminal (32.768 kHz)
83	XCOU	O	Sub clock oscillation terminal
84	RESET	I	Reset input
85	BAT OFF	I	Battery OFF detection signal L : OFF
86	RXD	I	RS-232C RXD input terminal
87	S. REQ	I	Serial communication request signal L : Request
88~90	NOT USED	-	-
91~93	SCAN OUT 0~2	O	Key matrix output
94	NOT USED	-	-
95	LCD ON	O	LCD monitor power $\overline{\text{ON/OFF}}$ signal H : ON
96	ASIC TEST 0	O	ASIC reset control signal
97	ASIC RESET	O	ASIC reset signal L : Reset output
98	ASIC TEST 1	O	ASIC reset control signal
99	AVSS	-	A/D converter GND power terminal
100	BATTERY	I	Battery voltage input (analog input)

Table 4-1. 8-bit Microprocessor Port Specification

2. Internal Communication Bus

The SY1 circuit board carries out overall control of camera operation by detecting the input from the keyboard and the condition of the camera circuits. The 8-bit microprocessor reads the signals from each sensor element as input data and outputs this data to the camera circuits (ASIC) or to the LCD display device as operation mode setting data. Fig. 4-1 shows the internal communication between the 8-bit microprocessor and ASIC.

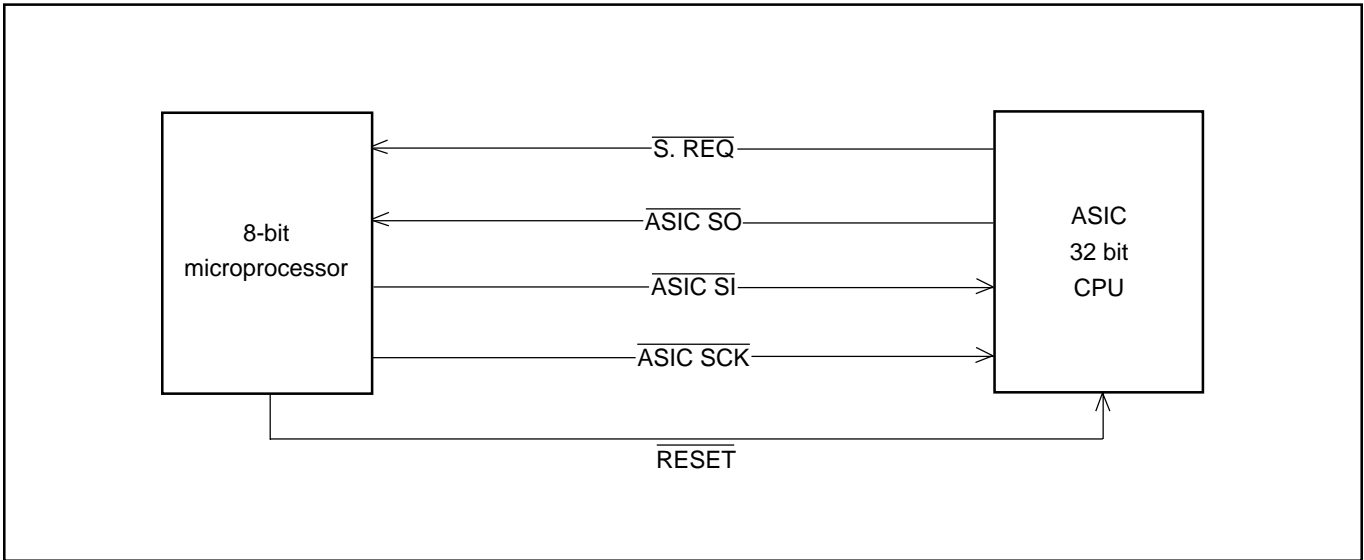

Fig. 4-1 Internal Bus Communication System

3. Key Operaiton

For details of the key operation, refer to the instruction manual.

SCAN OUT \ SCAN IN	0	1	2	3	4
0	▲	◀	▶	▼	MACRO
1	SHUTTER 1st	SHUTTER 2nd	CAMERA	PLAY	-
2	BARRIER	CARD LID	MODE	SET	TEST

Table 4-2. Key Operation

4. Power Supply Control

The 8-bit microprocessor controls the power supply for the overall system.

The following is a description of how the power supply is turned on and off. When the battery is attached, a regulated 3.3 V voltage is normally input to the 8-bit microprocessor (IC301) by IC303, so that clock counting and key scanning is carried out even when the power switch is turned off, so that the camera can start up again. When the battery is removed, the 8-bit microprocessor operates in sleep mode using the backup capacitor. At this time, the 8-bit microprocessor only carries out clock counting, and waits in standby for the battery to be attached again. When a switch is operated, the 8-bit microprocessor supplies power to the system as required.

The 8-bit microprocessor first sets both the $\overline{P(A) ON}$ signal at pin (70) and the $\overline{P ON}$ signal at pin (71) to low, and then turns on the DC/DC converter. After this, High signals are output from pin (97) so that the ASIC is set to the active condition. If the LCD monitor is on, the LCD ON signal at pin (95) set to Low, and the DC/DC converter for the LCD monitor is turned on.

		ASIC, memory	RS232C driver	CCD	8bit CPU	MODE LCD	LCD MONITOR
Power voltage		3.3 V	3.3 V	5 V (A), -7.5 V, +15 V etc.	3.2 V (ALWAYS)	3.2 V (ALWAYS)	5V (L), 15 V, +12V etc.
Lens cover close		OFF	OFF	OFF	32KHz	OFF	OFF
Lens cover open	Power switch ON- Auto power down	OFF	OFF	OFF	4MHz	ON	OFF
	Shutter switch ON	ON	ON	ON OFF	4MHz	ON	OFF
	Resolution, Flash, Self timer switch ON	OFF	OFF	OFF	4MHz	ON	OFF
	LCD finder	ON	ON	ON	4MHz	ON	ON
Playback		ON	ON	OFF	4MHz	ON	ON

Table 4-3. Camera Mode (Battery Operation)

		ASIC, memory	RS232C Driver	CCD	8bit CPU	MODE LCD	LCD MONITOR
Power voltage		3.3 V	3.3 V	5 V (A), -7.5 V, +12 V etc.	3.2 V (ALWAYS)	3.2 V (ALWAYS)	5 V (L) +12V etc.
Lens cover close		OFF	OFF	OFF	32 KHz	OFF	OFF
Lens cover open	Power switch ON- Auto power down	OFF	OFF	OFF	4 MHz	ON	OFF
	Take a picture	ON	ON	ON OFF	4 MHz	ON	OFF
	Erase image	ON	ON	OFF	4 MHz	ON	OFF
	Download image	ON	ON	OFF	4 MHz	ON	OFF
	Continuous image	ON	ON	ON	4 MHz	ON	OFF
	Message from host	ON	ON	ON	4 MHz	ON	OFF

Note) P. SAVE = Power save mode, 4 MHz = Main clock operation, 32 kHz = Sub clock operation

Table 4-4. Host Mode (Battery Operation)

2. DISASSEMBLY

2-1. REMOVAL OF CABINET ASSEMBLY (FRONT) AND CABINET ASSEMBLY (BACK)

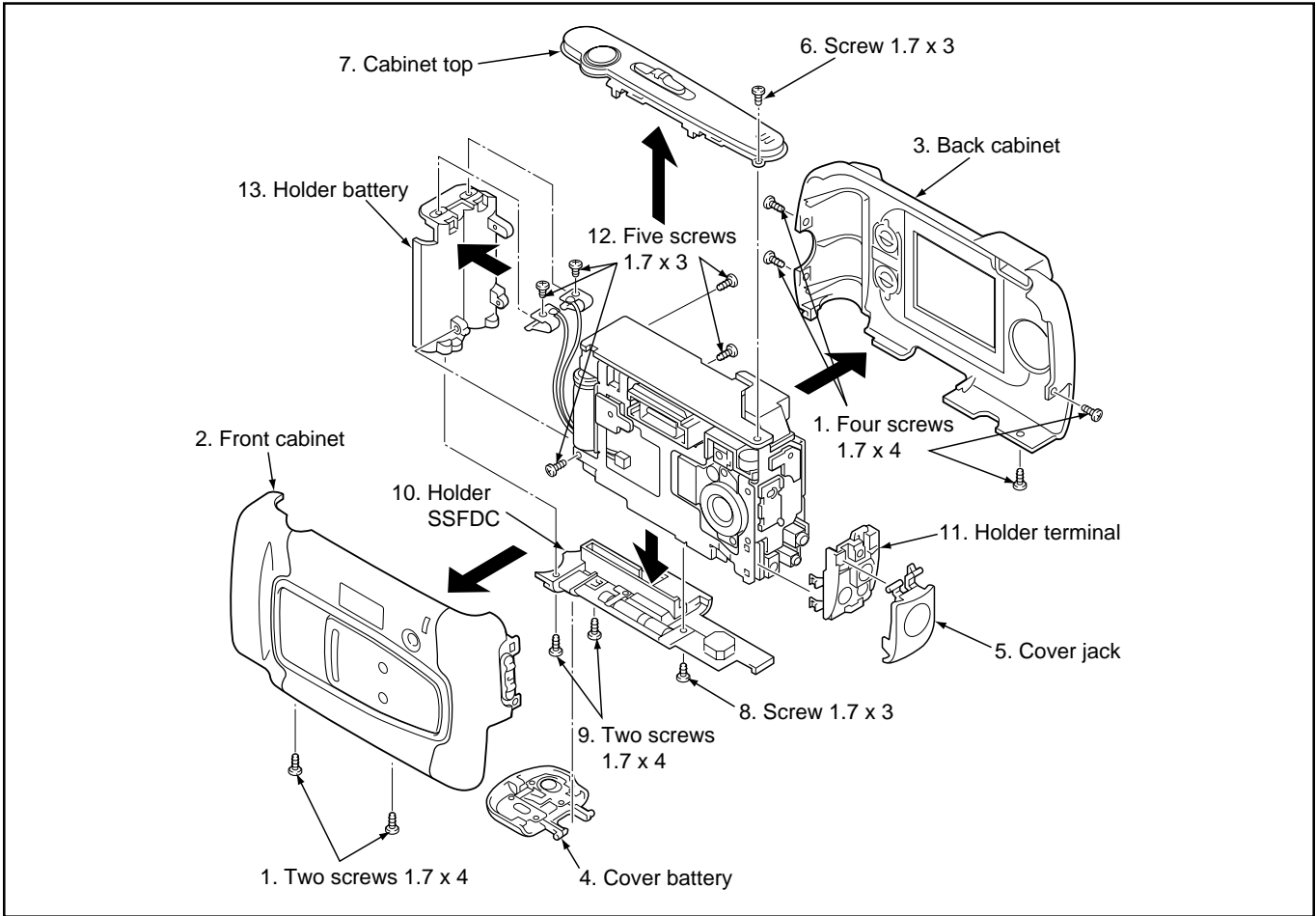

2-2. REMOVAL OF SY1 BOARD, TB2 BOARD AND TB1 BOARD

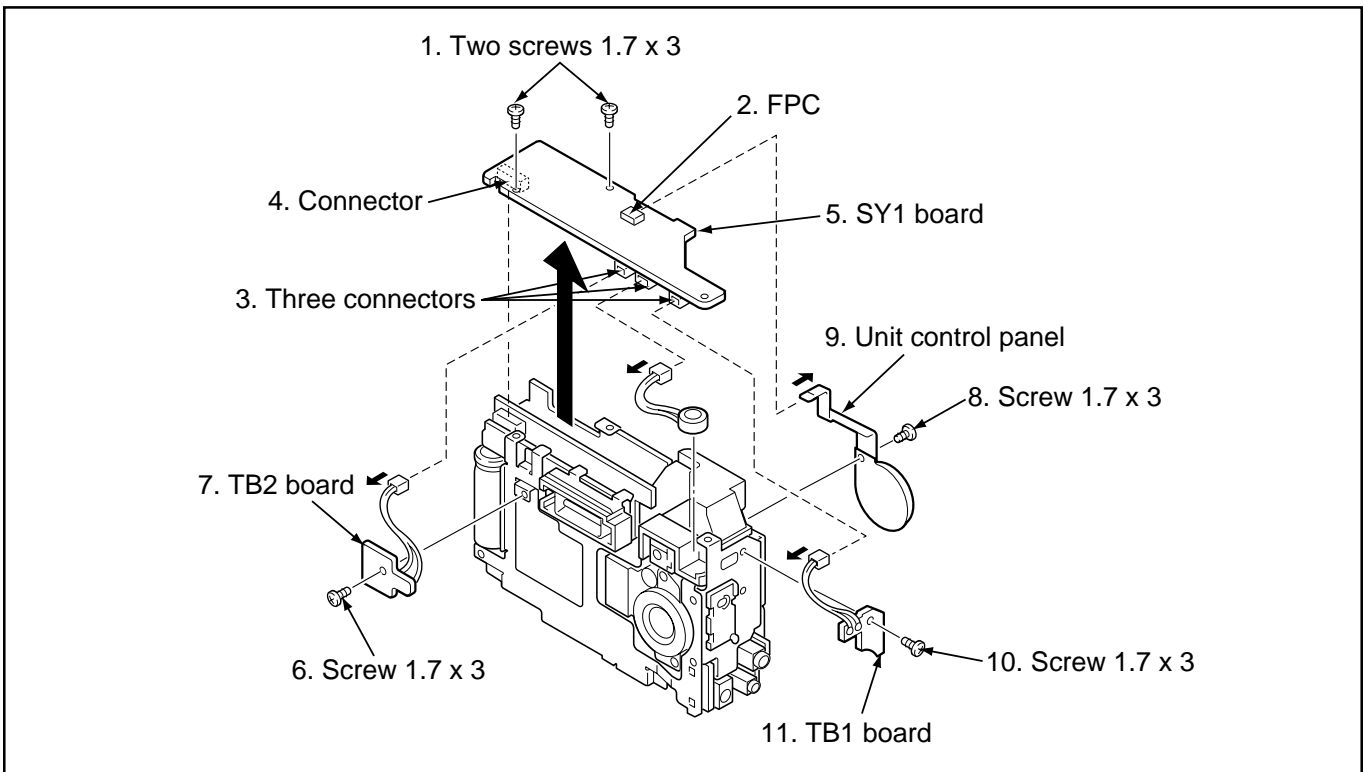

2-3. REMOVAL OF LENS VF AND PW1 BOARD

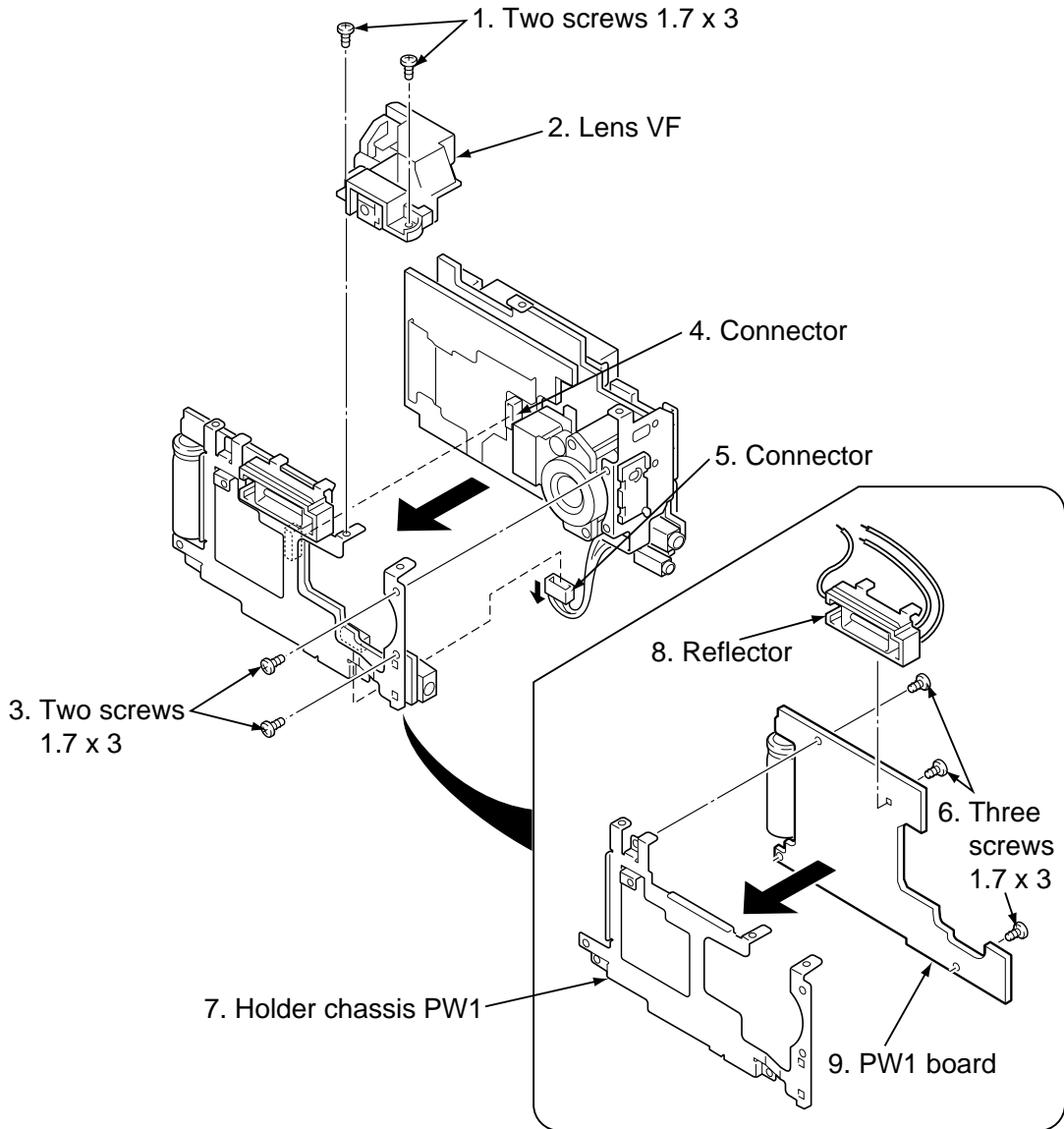

2-4. REMOVAL OF LCD, CA2 BOARD AND CA1 BOARD

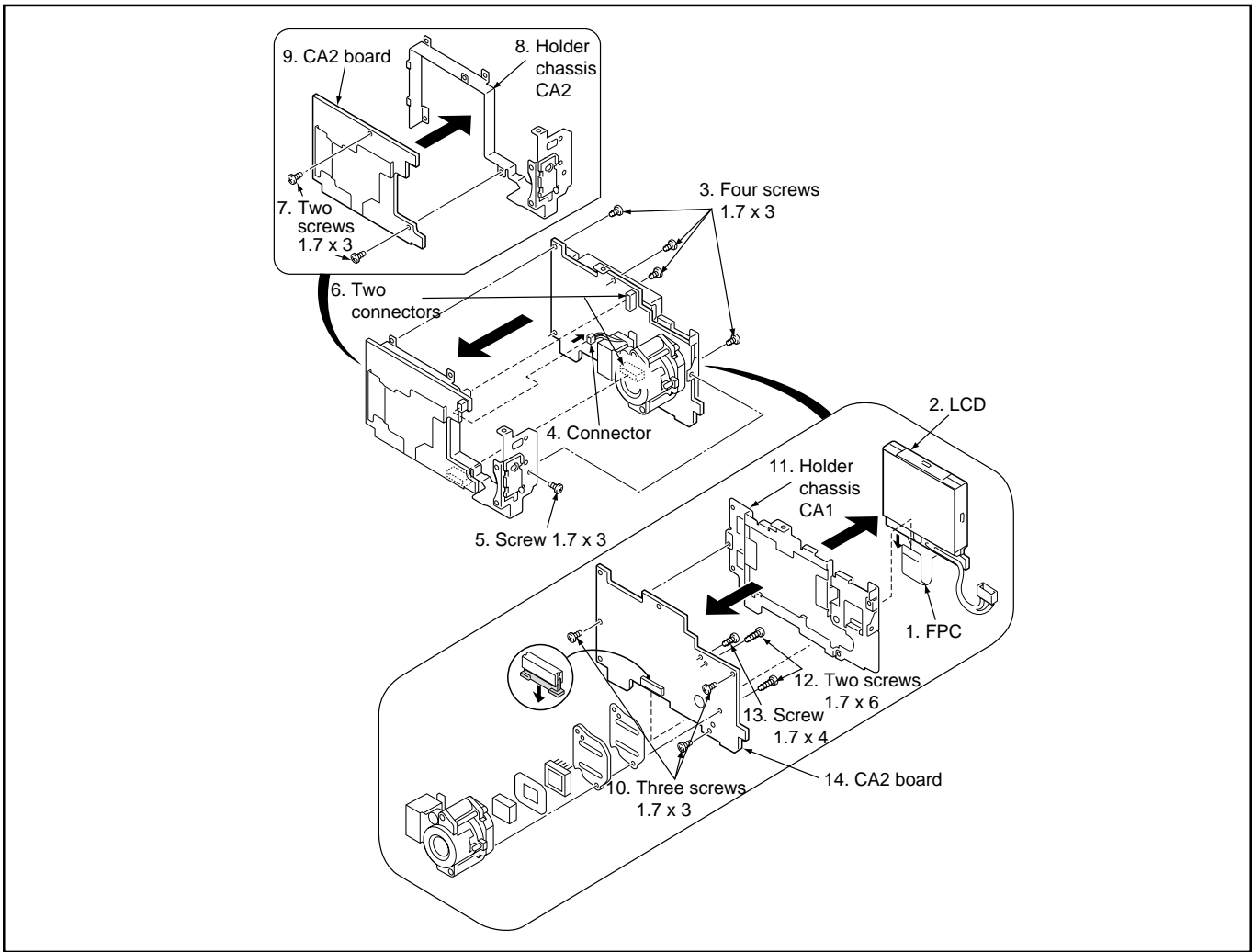

2-5. BOARD LOCATION

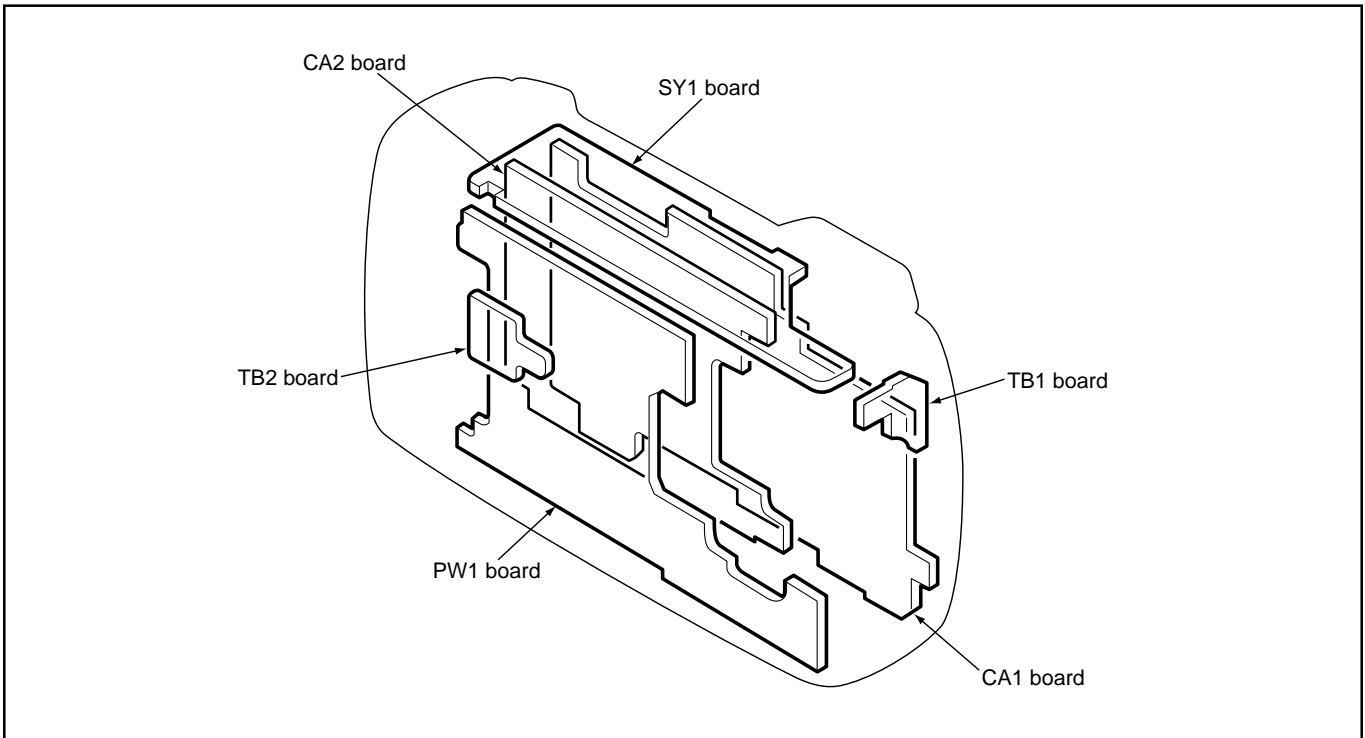

3. ELECTRICAL ADJUSTMENT

3-1. Table for Servicing Tools

Ref. No.	Name	Part code
J-1	Color viewer 5,100 K	VJ8-0007
J-2	Siemens star chart	
J-3	Calibration software	VJ8-0166
J-4	Extension cord	VJ8-0151

Note: J-1 color viewer is 100 - 110 VAC only.
J-2 Siemens star chart is the same as before models.

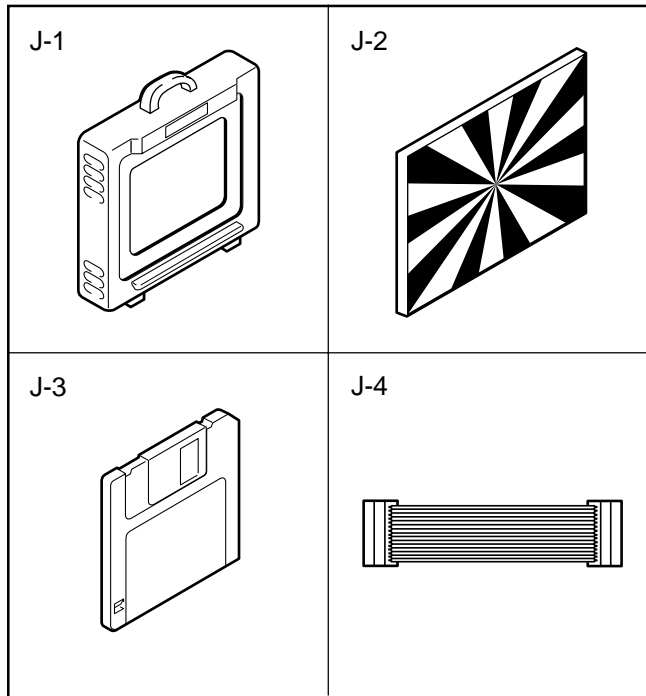

3-2. Equipment

1. Oscilloscope
2. Digital voltmeter
3. AC adaptor
4. IBM®-compatible PC
5. DC regulated power supply

3-3. Adjustment Items and Order

1. IC501 Frequency Adjustment
2. 5.0 V (D) Voltage Adjustment
3. 3.3 V (D) Voltage Adjustment
4. 12.4 V (L) Voltage Adjustment 1
5. 12.4 V (L) Voltage Adjustment 2
6. 5.8 V (L) Voltage Adjustment
7. CCD Defect Defect Adjustment
8. AWB Adjustment
9. Flange-back Adjustment
10. LCD Panel Adjustment
 - 10-1. LCD H AFC Adjustment
 - 10-2. LCD RGB Offset Adjustment
 - 10-3. LCD Gain Adjustment
 - 10-4. LCD Blue Brightness Adjustment
 - 10-5. LCD Red Brightness Adjustment

3-4. Setup

1. System requirements

- Windows 95 or 98
- IBM®-compatible PC with 486 or higher processor
- CD-ROM drive
- 3.5-inch high-density diskette drive
- Serial port with standard RS-232C interface
- 8 MB RAM
- Hard disk drive with at least 15 MB available
- VGA or SVGA monitor with at least 256-color display

2. Installing calibration software

1. Insert the calibration software installation diskette into your diskette drive.
2. Open the explorer.
3. Copy the DSC Cal folder on the floppy disk in the FD drive to a folder on the hard disk.

3. Color Viewer

Turn on the switch and wait for 30 minutes for aging to take place before using Color Pure.

4. Computer screen during adjustment

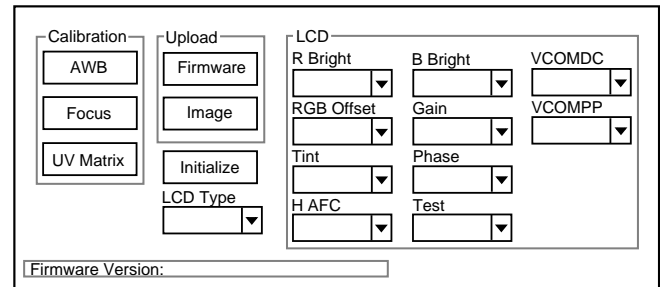

3-5. Connecting the camera to the computer

1. Turn off both camera and computer.
2. Locate the port cover on the side of the camera. Press on the arrows and slide the cover down to open it.
3. Line up the arrow on the cable connector with the notch on the camera's serial port. Insert the connector.
4. Locate a serial port on the back of your computer. You may have two serial ports labeled COM1 and COM2, or the ports may be labeled with icons. If you have two serial ports available, use port 1 to connect your camera.
5. Line up the serial connector on the cable with one of the serial ports on your computer, and insert the connector.
6. Turn on the camera and your computer system.

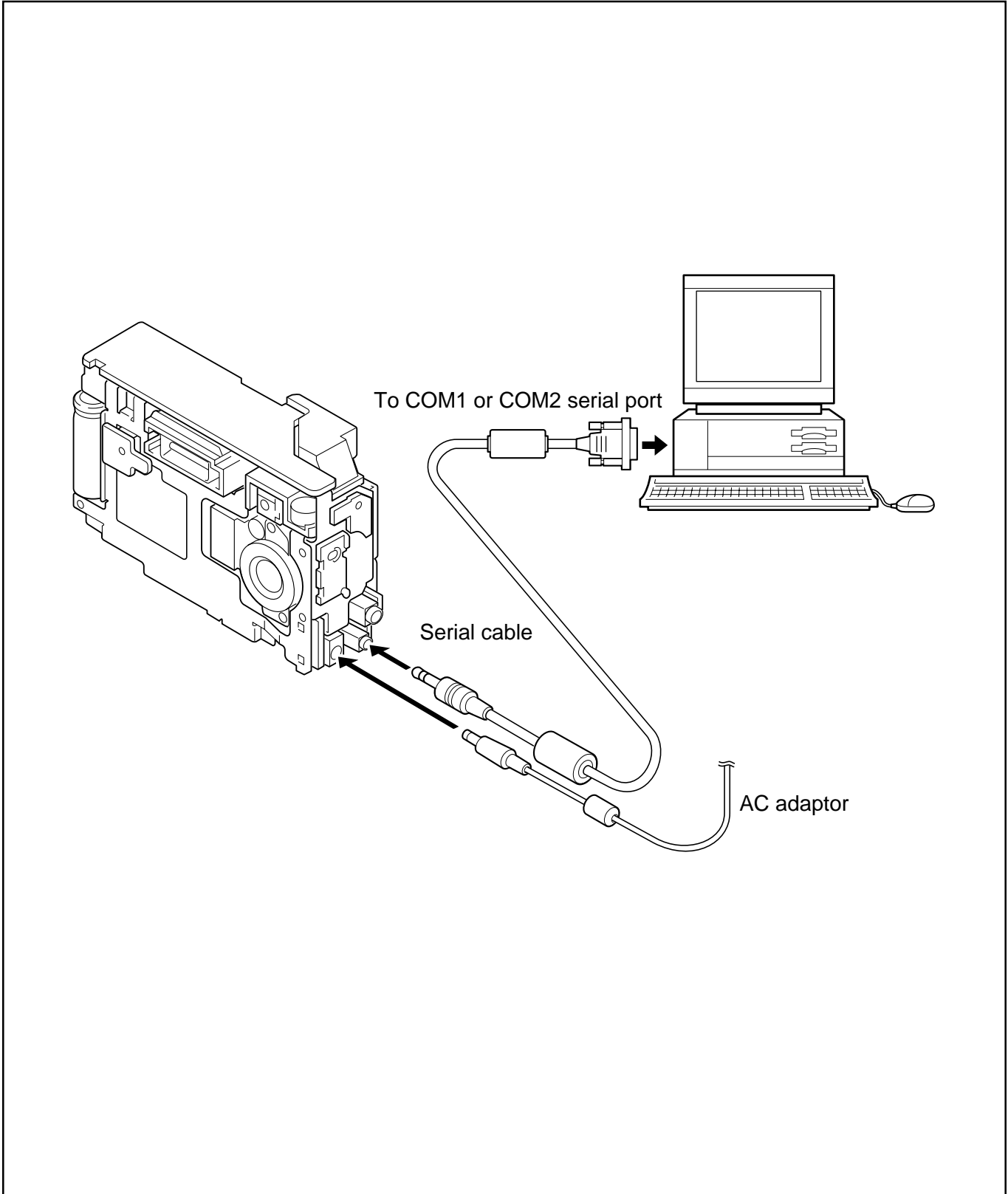

3-6. Adjust Specifications

[PW1 board (Side A/B)]

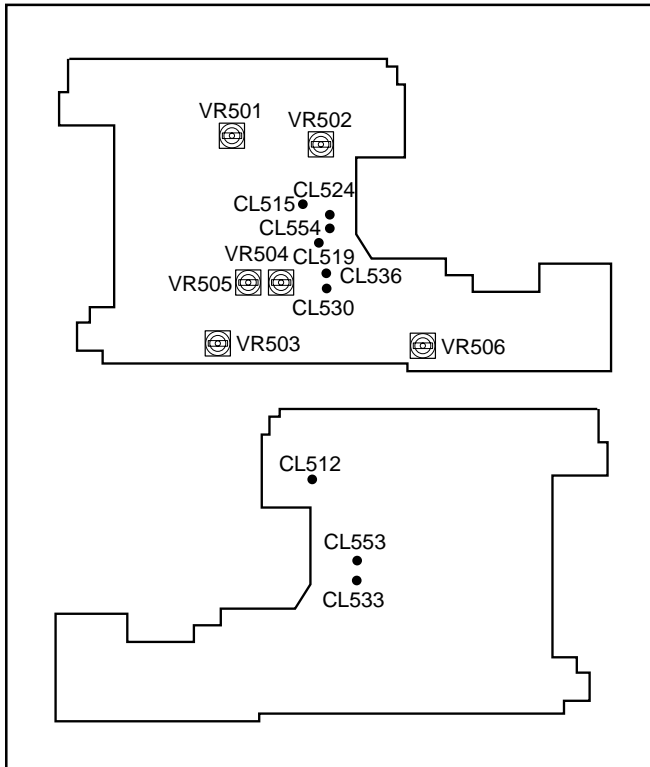

Note:

1. Voltage adjustment is necessary to repair in the PW1 board and replace the parts.
2. Power voltage set about +3.0 V.

Preparation:

1. Connect CN103 on the CA2 board and CN502 on the PW1 board with extension cord.
2. Open the barrier switch.
3. Set the view mode, and turn on the LCD.
4. Carry out initialization and display the through image on the LCD screen.

1. IC501 Oscillation Frequency Adjustment

Measuring Point	CL512
Measuring Equipment	Frequency counter
ADJ. Location	VR501
ADJ. Value	200 ± 1 kHz

Adjustment method:

1. Adjust with VR501 to 200 ± 1 kHz.

2. 5.0 V (D) Voltage Adjustment

Measuring Point	CL515
Measuring Equipment	Digital voltmeter
ADJ. Location	VR503
ADJ. Value	5.10 ± 0.05 V

Adjustment method:

1. Adjust with VR503 to 5.10 ± 0.05 V.

3. 3.3 V (D) Voltage Adjustment

Measuring Point	CL533 or CL553 or CL519
Measuring Equipment	Digital voltmeter
ADJ. Location	VR502
ADJ. Value	3.30 ± 0.03 V

Adjustment method:

1. Adjust with VR502 to 3.30 ± 0.03 V.

4. 12.4 V (L) Voltage Adjustment 1

Measuring Point	CL524 or CL554
Measuring Equipment	Digital voltmeter
ADJ. Location	VR505
ADJ. Value	12.40 ± 0.05 V

Adjustment method:

1. Set the play mode.
2. Adjust with VR505 to 12.40 ± 0.05 V.

5. 12.4 V (L) Voltage Adjustment 2

Measuring Point	CL524 or CL554
Measuring Equipment	Digital voltmeter
ADJ. Location	VR504
ADJ. Value	12.40 ± 0.05 V

Adjustment method:

1. Set the view mode, and turn on the LCD.
2. Adjust with VR504 to 12.40 ± 0.05 V.

6. 5.8 V (L) Voltage Adjustment

Measuring Point	CL530 or CL536
Measuring Equipment	Digital voltmeter
ADJ. Location	VR506
ADJ. Value	5.80 ± 0.05 V

Adjustment method:

1. Adjust with VR506 to 5.80 ± 0.05 V.

7. CCD Defect Detect Adjustment

Adjustment method:

1. Set the camera mode, and turn on the power switch to open the lens cover.
2. Double-click on the DscCaIV123b.
3. Select CCD Defect on the LCD "Test", and click the "Yes".
4. After the adjustment is completed, OK will display.
5. Close the lens cover.

8. AWB Adjustment

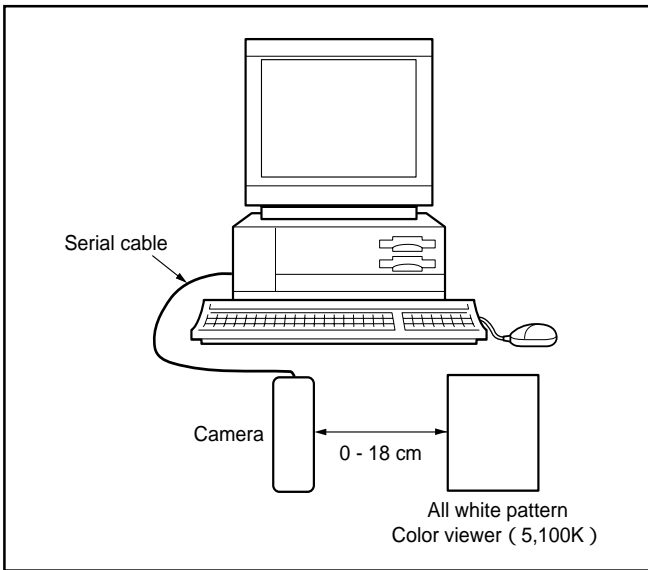

Preparation:

POWER switch: ON

Adjusting method:

1. Set the all white pattern so that it becomes a full picture.
(Do not enter any light.)
2. Double-click on the DscCalV123b.
3. Click the AWB, and click the Yes.
4. AWB adjustment value will appear on the screen.
5. Click the OK.

9. Frange-back Adjustment

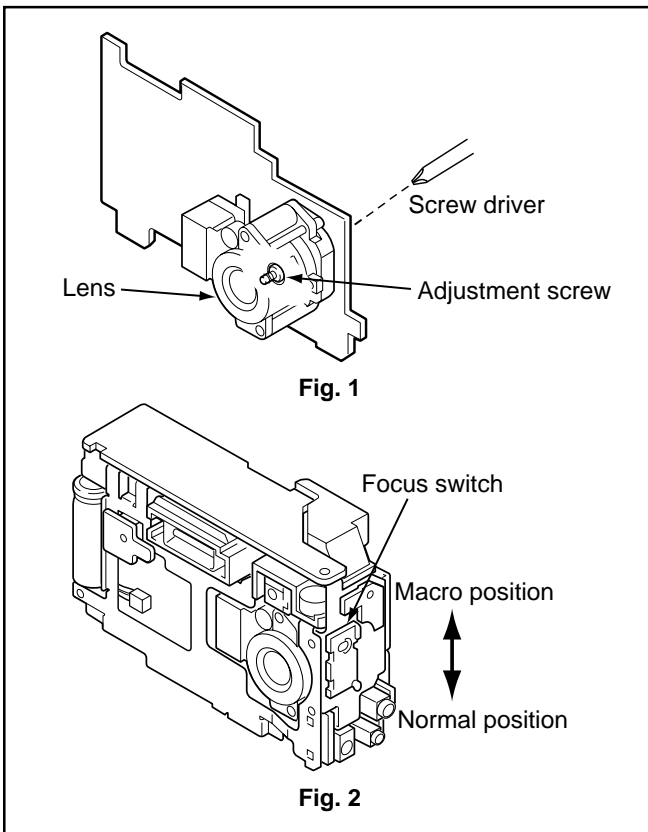

Preparation:

POWER switch: ON

Adjusting location:

Flange-back adjustment screw (Fig. 1)

Adjust the adjustment screw by turning it through the hole provided in the CA1 board. If this adjustment screw is turned counter-clockwise, the focal length of the lens will decrease, and if it is turned clockwise, the focal length will increase.

Adjustment method:

1. Display the image taken by the camera on the screen of a computer.
2. Set the focus switch at the normal position.
3. Project two Siemens star charts at a distance of 1.0 meters and 0.3 meters in front of the lens.
4. Turn the adjustment screw until the Siemens star which is 1.0 meters away is exactly in focus. Check that the Siemens star which is 0.3 meters from the front of the lens is out of focus at this time.
5. Project the Siemens star chart at a distance of 0.3 meters in front of lens. Check that it is out of focus at normal mode, and it is in focus at macro mode.
6. This adjustment location is integrated with the iris mechanism. After adjusting, make sure that no load has been placed on the iris mechanism and harness.

10. LCD Panel Adjustment

[CA1 board (Side B)]

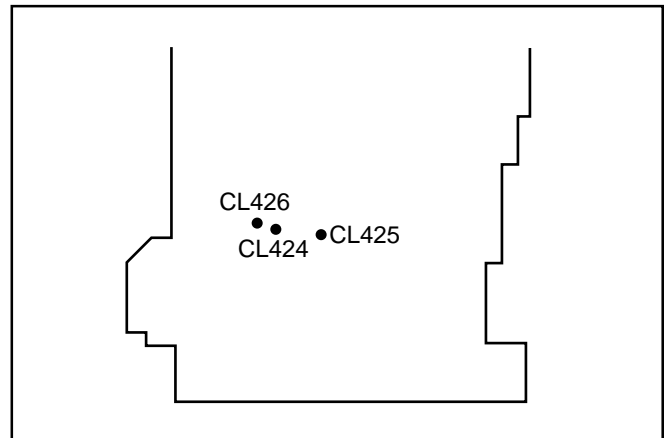

10-1. LCD H AFC Adjustment

Preparation:

POWER switch: ON

Adjusting method:

1. Double-click on the DscCalV123b .
2. Select 0 on the LCD "H AFC".
3. While watching the LCD monitor, adjust "H AFC" so that the edge of the LCD adjustment frame are the same distance from the left and right edge of the LCD screen. (A = B)

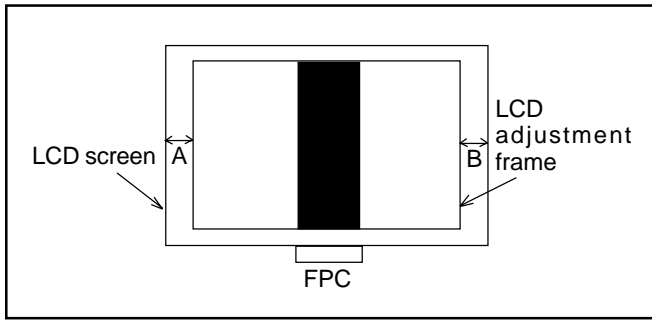

10-2. LCD RGB Offset Adjustment

Adjusting method:

1. Adjust LCD "RGB offset" so that the amplitude of the CL424 waveform is $7.5 \text{ Vp-p} \pm 0.3 \text{ V}$.

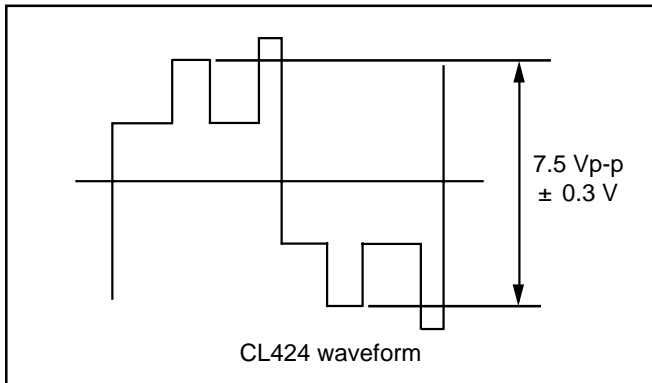

10-3. LCD Gain Adjustment

Adjusting method:

1. Adjust LCD "Gain" so that the amplitude of the CL424 waveform is $4.0 \text{ Vp-p} \pm 0.15 \text{ V}$.

Note:

10-2. LCD RGB Offset adjustment should always be carried out first.

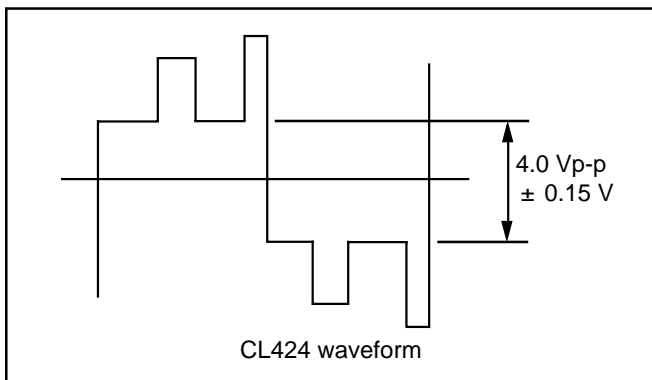

10-4. LCD Blue Brightness Adjustment

Adjusting method:

1. Adjust LCD "B Bright" so that the amplitude of the CL426 waveform is $\pm 0.2 \text{ V}$ with respect to the CL424 (VG) waveform.

Note:

10-2. LCD RGB Offset adjustment and 10-3. LCD Gain adjustment should always be carried out first.

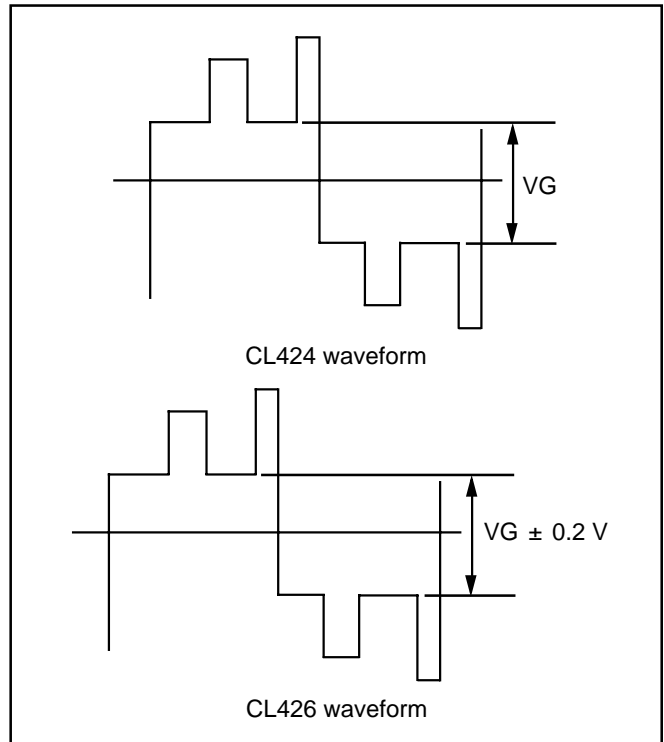

10-5. LCD Red Brightness Adjustment

Adjusting method:

1. Adjust LCD "R Bright" so that the amplitude of the CL425 waveform is $\pm 0.2 \text{ V}$ with respect to the CL424 (VG) waveform.

Note:

10-2. LCD RGB Offset adjustment and 10-3. LCD Gain adjustment should always be carried out first.

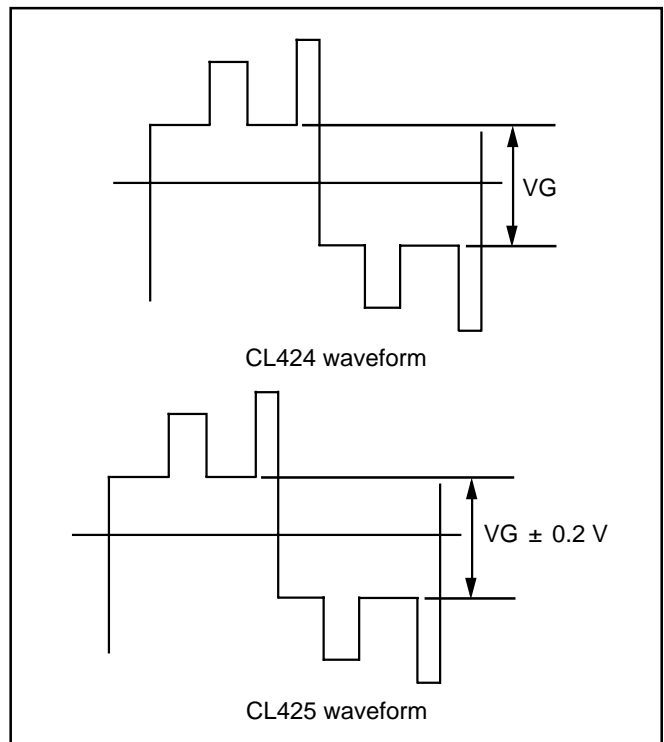

4. TROUBLESHOOTING GUIDE

POWER LOSS INOPERATIVE

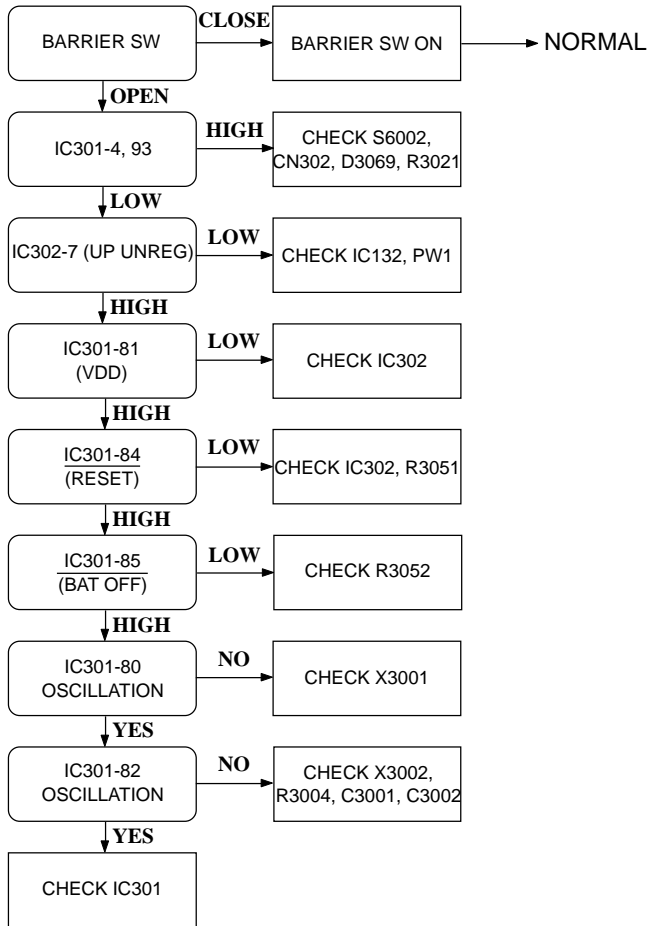

TAKING INOPERATIVE

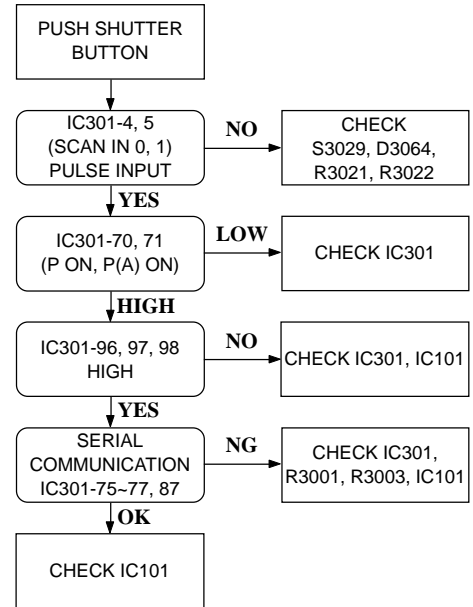

NO PICTURE

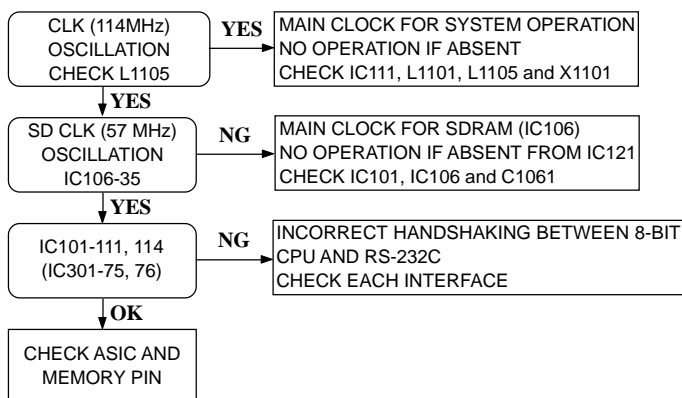

5 . PARTS LIST

LOCATION	PARTS NO.	DESCRIPTION	LOCATION	PARTS NO.	DESCRIPTION
CABINET & CHASSIS PARTS 1					
1	636 056 2479	ASSY,COVER LENS-SR662/E	16	636 055 5853	HOLDER TERMINAL-SR662/J
2	636 055 5600	COVER FRONT-SR662/J	17	636 056 0956	DEC MONITOR-SR662/E
3	636 055 5785	DEC WINDOW VF-SR662/J	18	636 055 9080	ASSY,CABINET BACK-SR662/J
4	636 055 5785	DEC WINDOW VF-SR662/J	19	636 055 5938	KNOB POWER-SR662/J
5	636 055 5792	DEC STRAP-SR662/J	20	636 057 0214	SPRING COMP RELEASE-662/J
6	636 055 9066	ASSY,CABI FRONT-SR662/J	21	636 055 9042	ASSY,BUTTON SHUTTER-662/J
7	636 055 5846	HOLDER COVER LENS-SR662/J	22	636 056 0932	CABINET TOP-SR662/E
8	636 055 6041	SPRING LENS-SR662/J	23	636 055 5990	SLIDE KNOB POWER-SR662/J
9	636 055 5921	KNOB MACRO-SR662/J	24	636 055 6058	TERMINAL BATTERY A-SR662/J
10	636 055 5976	SLIDE KNOB MACRO-SR662/J	25	636 055 6065	TERMINAL BATTERY B-SR662/J
11	636 055 6010	SPRING P SSFDC-SR662/J	26	636 055 5891	HOLDER BATTERY-SR662/J
12	636 055 9103	COMPL,COVER BATTERY-662/J	27	636 055 4658	LABEL CAUTION BATT-SX112/J
13	636 055 5761	COVER SSFDC-SR662/J	101	411 017 7508	SCR PAN PCS 1.4X2
14	636 056 6460	SHIELD TAPE SSFDC-SR662/J	102	411 178 8802	SCR S-TPG PAN PCS 1.7X2.0
15	636 055 5907	HOLDER SSFDC-SR662/J	103	411 175 5705	SCR PAN PCS 1.7X3
16	636 055 5747	COVER JACK-SR662/J	104	411 178 9403	SCR S-TPG PAN PCS 1.7X4.0
			105	411 177 8407	SCR S-TPG PAN PCS 1.7X3

N.S.P.: Not available as service parts.

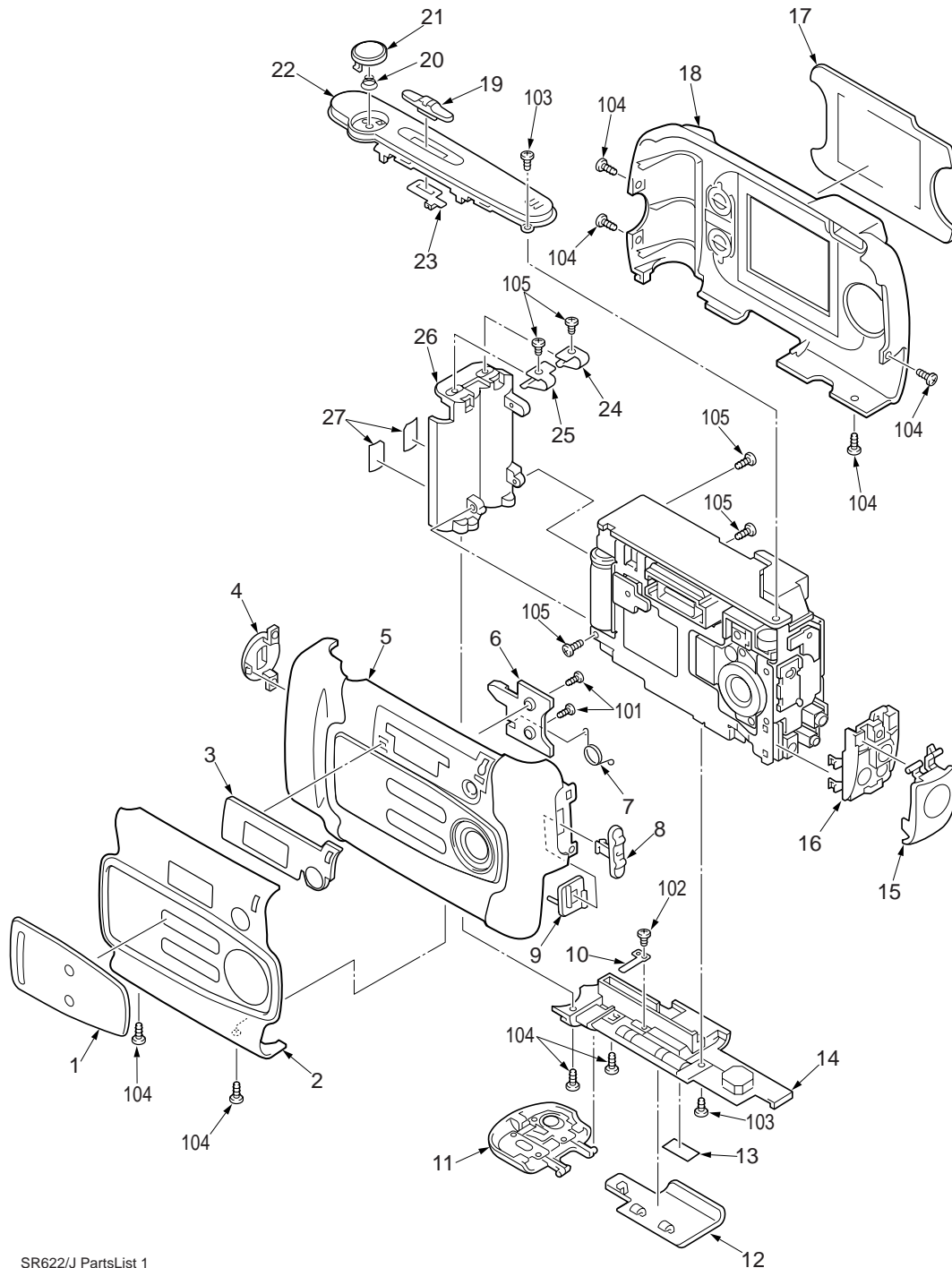

LOCATION	PARTS NO.	DESCRIPTION	LOCATION	PARTS NO.	DESCRIPTION
CABINET & CHASSIS PARTS 2					
1	645 029 2170	LENS(ASSY)	16	636 055 4276	COMPL PWB,CA-2,EXCEPT VPC-X360
2	645 032 5854	OPTICAL FILTER	16	636 056 6705	COMPL PWB,CA-2,VPC-X360 ONLY
3	636 052 2183	SPACER	17	636 055 4290	COMPL PWB,PW-1
4	636 052 9199	ASSY,UNIT,CCD	18	636 055 5822	HOLDER CHASSIS PW1-662/J
5	636 052 2190	SPACER,INSULATOR	19	636 055 4313	COMPL PWB,TB-2
6	636 057 3093	SPACER CHASSIS PW1-SR662J	20	636 055 8892	COMPL,REFLECTOR
7	636 055 4252	COMPL PWB,CA-1,VPC-X360 ONLY	21	636 055 4283	COMPL PWB,SY-1
7	636 056 2431	COMPL PWB,CA-1,EXCEPT VPC-X360	22	636 055 5877	HOLDER VF-SR662/J
8	636 055 5839	HOLDER CHASSIS CA1-662/J	23	645 023 4248	ASSY,LENS,VF
9	645 039 9732	UNIT,CONTROL PANEL	24	636 055 5952	REFLECTOR VF-SR662/J
10	636 056 1298	SPACER UNIT C.P-SR662/J	25	645 030 0639	MICROPHONE
11	645 032 2167	LCD	26	636 056 2615	ADHESIVE TAPE VF-SR661/J
12	636 055 9189	SPACER MONITOR BTM-662/J	103	411 175 5705	SCR PAN PCS 1.7X3
13	636 055 5983	SLIDE MACRO-SR662/J	106	411 170 8602	SCR S-TPG PAN 2X5
14	636 055 4306	COMPL PWB,TB-1	107	411 169 9603	SCR S-TPG PAN PCS 1.7X6E
15	636 055 5815	HOLDER CHASSIS CA2-662/J	108	411 020 0701	SCR PAN PCS 1.7X4

N.S.P.: Not available as service parts.

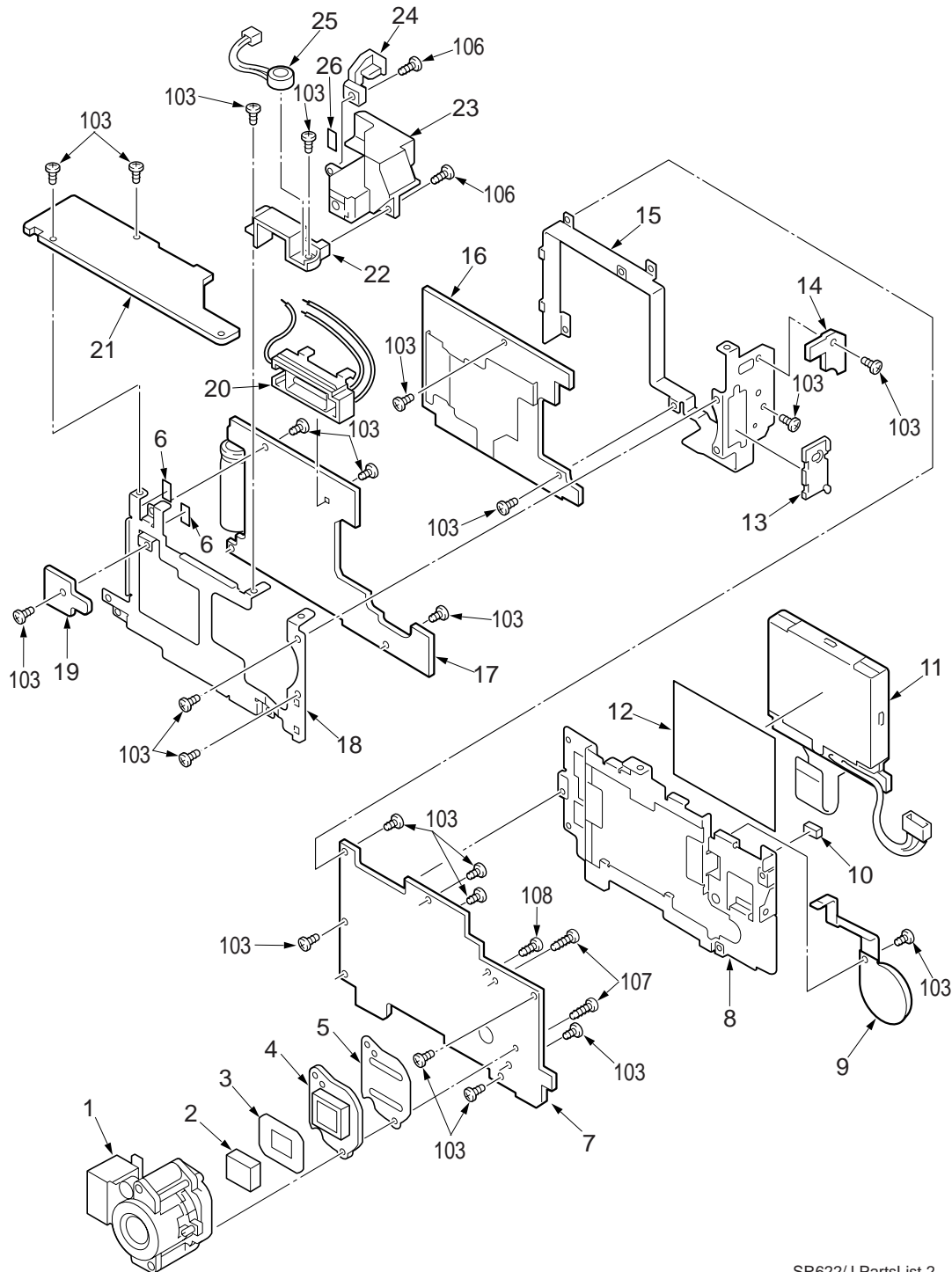

ELECTRICAL PARTS

Note:

1. Materials of Capacitors and Resistors are abbreviated as follows ;

Resistors		Capacitors	
MT-FILM	Metallized Film Resistor	MT-POLYEST	Metallized Polyester Capacitor
MT-GLAZE	Metallized Glaze Resistor	MT-COMPO	Metallized Composite Capacitor
OXIDE-MT	Oxide Metallized Film Resistor	TA-SOLD	Tantalum Solid Capacitor
		AL-SOLID	Aluminum Solid Capacitor
		NP-ELECT	Non-Polarized Electrolytic Capacitor
		OS-SOLID	Aluminum Solid Capacitors with Organic Semiconductive Electrolytic Capacitor
			Double Layered Electrolytic Capacitor
		DL-ELECT	

2. Tolerance of Capacitor (10pF over) and Resistor are noted with follow symboles.

F	1%	G	2%	J	5%	K	10%
M	20%	N	30%	Z	+80%		-20%

3. Capacitors

U : µF P : pF

4. Inductors

UH : µH MH : mH

5. N.S.P. : Not available as service parts.

LOCATION	PARTS NO.	DESCRIPTION	LOCATION	PARTS NO.	DESCRIPTION
COMPL PWB,CA-1			C1702	403 332 9503	CERAMIC 1U M 6.3V
	636 055 4252	VPC-X360 ONLY	C1703	403 311 4505	CERAMIC 1000P K 50V
	636 056 2431	EXCEPT VPC-X360	C1705	403 312 6003	CERAMIC 39P J 50V
	(SEMICONDUCTORS)		C1706	403 319 3005	CERAMIC 220P J 25V
Q1701	405 102 5609	TR 2SD1819A-R	C1707	403 311 3409	CERAMIC 0.01U K 16V
OR	405 092 4101	TR 2SC4081-R	C1708	403 207 0307	CERAMIC 1U Z 16V
Q1702	405 115 6907	TR DTC114EE	C1709	403 157 7302	CERAMIC 6800P K 50V
Q1707	405 102 5500	TR 2SB1218A-R	C1710	403 332 9503	CERAMIC 1U M 6.3V
OR	405 092 4200	TR 2SA1576-R	C1711	403 283 6309	CERAMIC 1U Z 10V
Q2001	405 102 5609	TR 2SD1819A-R	C1712	403 332 9503	CERAMIC 1U M 6.3V
OR	405 092 4101	TR 2SC4081-R	C1714	403 311 3409	CERAMIC 0.01U K 16V
Q2002	405 131 3607	TR DTA144EUA	C1715	403 311 3409	CERAMIC 0.01U K 16V
Q2003	405 102 5609	TR 2SD1819A-R	C1717	403 322 3504	CERAMIC 22U Z 10V
OR	405 092 4101	TR 2SC4081-R	C1718	403 338 0405	CERAMIC 0.47U K 25V
Q9001	405 079 6203	TR 2SC4399-4	C1719	403 338 0405	CERAMIC 0.47U K 25V
OR	405 079 6302	TR 2SC4399-5	C1720	403 338 0405	CERAMIC 0.47U K 25V
Q9002	405 133 8907	TR DTC114EUA	C1721	403 338 0405	CERAMIC 0.47U K 25V
Q9007	405 129 2308	TR UMZ1N	C1722	403 283 6309	CERAMIC 1U Z 10V
OR	405 106 4806	TR XP4601	C1723	403 332 9503	CERAMIC 1U M 6.3V
Q9010	405 102 5609	TR 2SD1819A-R	C1724	403 309 8607	CERAMIC 18P J 50V,EXCEPT VPC-X360
OR	405 092 4101	TR 2SC4081-R	C1724	403 311 4505	CERAMIC 1000P K 50V,VPC-X360 ONLY
	(INTEGRATED CIRCUITS)		C1726	403 207 0307	CERAMIC 1U Z 16V
IC171	409 452 4206	IC LV4127W	C1727	403 332 9503	CERAMIC 1U M 6.3V
IC174	409 423 6802	IC TK11245BM	C1729	403 311 3409	CERAMIC 0.01U K 16V
IC175	409 400 9109	IC TC7SET08FU	C1730	403 312 6805	CERAMIC 0.1U Z 16V
IC201	409 432 2505	IC LMV321M7X	C1731	403 347 9406	CERAMIC 0.22U Z 10V
IC202	409 432 2604	IC LMV821M7X	C1739	403 327 0300	CERAMIC 10U Z 25V
IC902	409 392 9101	IC 74VHC04MTC	C1741	403 325 4409	CERAMIC 0.068U Z 16V
IC904	409 366 9700	IC CXD1267AN	C1742	403 347 9406	CERAMIC 0.22U Z 10V
IC905	409 418 9702	IC AD9802JSTRL	C1775	403 207 0307	CERAMIC 1U Z 16V
IC909	409 407 0505	IC TK11331BM	C1776	403 332 9503	CERAMIC 1U M 6.3V
	(DIODES)		C1777	403 334 3806	CERAMIC 10U K 6.3V
D1701	407 166 0606	DIODE MA365	C1778	403 332 8209	CERAMIC 10U M 16V
D9011	407 187 8407	ZENER DIODE UDZ16B	C1779	403 332 9503	CERAMIC 1U M 6.3V
D9019	407 149 0807	DIODE 1SS355	C2010	403 323 6306	CERAMIC 0.1U K 16V
D9020	407 198 9905	DIODE MA727	C2011	403 272 5603	CERAMIC 0.033U K 16V
D9021	407 198 9905	DIODE MA727	C2012	403 311 7704	CERAMIC 4700P K 25V
D9022	407 198 9905	DIODE MA727	C2014	403 332 9503	CERAMIC 1U M 6.3V
	(CRYSTAL DEVICES)		C2015	403 332 9503	CERAMIC 1U M 6.3V
X1701	645 025 6004	OSC,CRYSTAL 3.579545MHZ,VPC-X360 ONLY	C2016	403 332 9503	CERAMIC 1U M 6.3V
X1701	645 030 0431	OSC,CRYSTAL 4.433619MHZ, EXCEPT VPC-X360	C2017	403 155 2101	CERAMIC 1500P K 50V
	(INDUCTORS)		C2018	403 332 9503	CERAMIC 1U M 6.3V
L1701	645 021 1607	INDUCTOR,10U J	C2019	403 334 3806	CERAMIC 10U K 6.3V
L1702	645 021 1607	INDUCTOR,10U J	C9003	403 315 6406	CERAMIC 180P J 25V
L1703	645 020 1868	INDUCTOR,750 OHM	C9004	403 320 5203	CERAMIC 0.33U K 16V
L1704	645 020 2070	INDUCTOR,750 OHM	C9005	403 207 0307	CERAMIC 1U Z 16V
L1705	645 020 1875	INDUCTOR,1500 OHM	C9006	403 311 3409	CERAMIC 0.01U K 16V
L1706	645 020 1868	INDUCTOR,750 OHM	C9007	403 312 6805	CERAMIC 0.1U Z 16V
L1707	645 014 8064	INDUCTOR,120 OHM	C9008	403 155 1807	CERAMIC 0.01U K 25V
L1708	645 020 2070	INDUCTOR,750 OHM	C9010	403 320 5500	CERAMIC 1U Z 25V
L1709	645 020 2070	INDUCTOR,750 OHM	C9012	403 320 5500	CERAMIC 1U Z 25V
L9001	645 001 4512	INDUCTOR,10U K	C9013	403 311 3409	CERAMIC 0.01U K 16V
L9010	645 020 1875	INDUCTOR,1500 OHM	C9014	403 311 7605	CERAMIC 2200P K 50V
L9010	645 020 1882	INDUCTOR,1800 OHM	C9016	403 068 0409	CERAMIC 0.1U Z 25V
	(CAPACITORS)		C9018	403 311 3409	CERAMIC 0.01U K 16V
C1700	403 312 6805	CERAMIC 0.1U Z 16V	C9019	403 320 5500	CERAMIC 1U Z 25V
			C9020	403 311 5809	CERAMIC 47P J 50V
			C9021	403 164 0204	CERAMIC 0.1U Z 25V

LOCATION	PARTS NO.	DESCRIPTION	LOCATION	PARTS NO.	DESCRIPTION
X1101	645 024 0461	OSC,CRYSTAL 17.734476MHZ, EXCEPT VPC-X360	R1014	401 225 7902	MT-GLAZE 220 JA 1/16W
	(INDUCTORS)		R1015	401 225 0309	MT-GLAZE 33 JA 1/16W
L1101	645 016 0363	INDUCTOR,600 OHM	R1016	401 225 0309	MT-GLAZE 33 JA 1/16W
L1103	645 038 2161	INDUCTOR,120 OHM	R1017	401 225 0309	MT-GLAZE 33 JA 1/16W
L1105	645 020 1899	INDUCTOR,68 OHM	R1018	401 225 0309	MT-GLAZE 33 JA 1/16W
L1301	645 010 0987	INDUCTOR,100U K	R1019	401 225 0309	MT-GLAZE 33 JA 1/16W
L1501	645 004 1990	INDUCTOR,47U K	R1020	401 225 7902	MT-GLAZE 220 JA 1/16W
L1502	645 004 2409	INDUCTOR,33U J	R1021	401 225 7902	MT-GLAZE 220 JA 1/16W
L1601	645 016 0349	INDUCTOR,600 OHM	R1022	401 225 7902	MT-GLAZE 220 JA 1/16W
L1602	645 016 0349	INDUCTOR,600 OHM	R1023	401 225 7902	MT-GLAZE 220 JA 1/16W
	(CAPACITORS)		R1024	401 225 7902	MT-GLAZE 220 JA 1/16W
C1030	403 312 6805	CERAMIC 0.1U Z 16V	R1025	401 225 7902	MT-GLAZE 220 JA 1/16W
C1031	403 312 6805	CERAMIC 0.1U Z 16V	R1026	401 225 7902	MT-GLAZE 220 JA 1/16W
C1032	403 312 6805	CERAMIC 0.1U Z 16V	R1030	401 225 0705	MT-GLAZE 56K JA 1/16W
C1033	403 312 6805	CERAMIC 0.1U Z 16V	R1036	401 226 1503	MT-GLAZE 0.000 ZA 1/16W
C1034	403 312 6805	CERAMIC 0.1U Z 16V	R1037	401 226 1503	MT-GLAZE 0.000 ZA 1/16W
C1035	403 312 6805	CERAMIC 0.1U Z 16V	R1038	401 226 1503	MT-GLAZE 0.000 ZA 1/16W
C1036	403 312 6805	CERAMIC 0.1U Z 16V	R1039	401 226 1503	MT-GLAZE 0.000 ZA 1/16W
C1037	403 312 6805	CERAMIC 0.1U Z 16V	R1052	401 262 1604	MT-GLAZE 2.2K DC 1/16W
C1038	403 312 6805	CERAMIC 0.1U Z 16V	R1053	401 262 2304	MT-GLAZE 1.0K DC 1/16W
C1039	403 312 6805	CERAMIC 0.1U Z 16V	R1054	401 262 1604	MT-GLAZE 2.2K DC 1/16W
C1040	403 312 6805	CERAMIC 0.1U Z 16V	R1055	401 262 2304	MT-GLAZE 1.0K DC 1/16W
C1041	403 312 6805	CERAMIC 0.1U Z 16V	R1056	401 262 2809	MT-GLAZE 200 DC 1/16W
C1042	403 312 6805	CERAMIC 0.1U Z 16V	R1057	401 262 2205	MT-GLAZE 820 DC 1/16W
C1046	403 312 6805	CERAMIC 0.1U Z 16V	R1058	401 262 2809	MT-GLAZE 200 DC 1/16W
C1051	403 334 3806	CERAMIC 10U K 6.3V	R1062	401 226 1503	MT-GLAZE 0.000 ZA 1/16W
C1052	403 312 6805	CERAMIC 0.1U Z 16V	R1063	401 105 7909	MT-GLAZE 0.000 ZA 1/16W
C1053	403 312 6805	CERAMIC 0.1U Z 16V	R1069	401 235 2102	MT-GLAZE 82 JA 1/16W
C1054	403 312 6805	CERAMIC 0.1U Z 16V	R1071	401 262 2106	MT-GLAZE 680 DC 1/16W
C1055	403 312 6805	CERAMIC 0.1U Z 16V	R1075	401 224 9006	MT-GLAZE 10K JA 1/16W
C1056	403 312 6805	CERAMIC 0.1U Z 16V	R1090	401 224 9006	MT-GLAZE 10K JA 1/16W
C1060	403 283 6309	CERAMIC 1U Z 10V	R1091	401 224 9006	MT-GLAZE 10K JA 1/16W
C1061	403 312 6003	CERAMIC 39P J 50V	R1092	401 224 9006	MT-GLAZE 10K JA 1/16W
C1070	403 113 3805	CERAMIC 1000P K 50V	R1099	401 224 9006	MT-GLAZE 10K JA 1/16W
C1071	403 312 6805	CERAMIC 0.1U Z 16V	R1102	401 224 8801	MT-GLAZE 100 JA 1/16W
C1072	403 312 6805	CERAMIC 0.1U Z 16V	R1104	401 037 5004	MT-GLAZE 0.000 ZA 1/16W
C1090	403 311 4505	CERAMIC 1000P K 50V	R1106	401 226 1503	MT-GLAZE 0.000 ZA 1/16W,EXCEPT VPC-X360
C1091	403 311 4505	CERAMIC 1000P K 50V	R1212	401 225 8107	MT-GLAZE 10 JA 1/16W
C1092	403 311 4505	CERAMIC 1000P K 50V	R1213	401 037 5004	MT-GLAZE 0.000 ZA 1/10W
C1101	403 155 1807	CERAMIC 0.01U K 25V	R1322	401 226 1503	MT-GLAZE 0.000 ZA 1/16W
C1102	403 309 8409	CERAMIC 10P D 50V	R1323	401 226 1503	MT-GLAZE 0.000 ZA 1/16W
C1103	403 343 8700	CERAMIC 1U M 12V	R1324	401 226 1503	MT-GLAZE 0.000 ZA 1/16W
C1104	403 155 1807	CERAMIC 0.01U K 25V	R1325	401 226 1503	MT-GLAZE 0.000 ZA 1/16W
C1105	403 155 1807	CERAMIC 0.01U K 25V	R1326	401 224 9006	MT-GLAZE 10K JA 1/16W
C1106	403 285 6802	TA-SOLID 10U M 6.3V	R1327	401 226 1503	MT-GLAZE 0.000 ZA 1/16W
C1109	403 309 8102	CERAMIC 5P C 50V,VPC-X360 ONLY	R1328	401 226 1503	MT-GLAZE 0.000 ZA 1/16W
C1109	403 309 8201	CERAMIC 6P D 50V,EXCEPT VPC-X360	R1329	401 225 1405	MT-GLAZE 47K JA 1/16W
C1111	403 309 8102	CERAMIC 5P C 50V,VPC-X360 ONLY	R1400	401 105 7909	MT-GLAZE 0.000 ZA 1/16W
C1111	403 309 8201	CERAMIC 6P D 50V,EXCEPT VPC-X360	R1401	401 224 9006	MT-GLAZE 10K JA 1/16W
C1211	403 323 6207	CERAMIC 1U K 10V	R1404	401 225 1207	MT-GLAZE 4.7K JA 1/16W
C1310	403 312 6805	CERAMIC 0.1U Z 16V	R1406	401 258 6606	MT-GLAZE 10K DC 1/16W
C1311	403 164 0204	CERAMIC 0.1U Z 25V	R1407	401 224 9006	MT-GLAZE 10K JA 1/16W
C1312	403 164 0204	CERAMIC 0.1U Z 25V	R1408	401 224 9006	MT-GLAZE 10K JA 1/16W
C1313	403 164 0204	CERAMIC 0.1U Z 25V	R1409	401 224 9600	MT-GLAZE 2.7K JA 1/16W
C1314	403 164 0204	CERAMIC 0.1U Z 25V	R1411	401 224 9006	MT-GLAZE 10K JA 1/16W
C1320	403 322 3504	CERAMIC 22U Z 10V	R1419	401 224 9006	MT-GLAZE 10K JA 1/16W
C1321	403 323 6009	CERAMIC 10U M 16V	R1420	401 224 9006	MT-GLAZE 10K JA 1/16W
C1401	403 312 6805	CERAMIC 0.1U Z 16V	R1507	401 263 9609	MT-GLAZE 91 DD 1/16W
C1402	403 314 8104	TA-SOLID 33U M 6.3V	R1508	401 263 9609	MT-GLAZE 91 DD 1/16W
C1403	403 312 6805	CERAMIC 0.1U Z 16V	R1509	401 262 2908	MT-GLAZE 220 DC 1/16W
C1450	403 207 0307	CERAMIC 1U Z 16V	R1510	401 226 2401	MT-GLAZE 560 JA 1/16W
C1501	403 334 3806	CERAMIC 10U K 6.3V	R1512	401 225 3805	MT-GLAZE 1.5K JA 1/16W
C1508	403 311 5007	CERAMIC 33P J 50V,EXCEPT VPC-X360	R1513	401 262 2007	MT-GLAZE 390 DC 1/16W,EXCEPT VPC-X360
C1508	403 312 6508	CERAMIC 56P J 50V,VPC-X360 ONLY	R1513	401 262 2601	MT-GLAZE 120 DC 1/16W,VPC-X360 ONLY
C1510	403 312 6805	CERAMIC 0.1U Z 16V	R1514	401 262 2304	MT-GLAZE 1.0K DC 1/16W
C1511	403 207 0307	CERAMIC 1U Z 16V	R1515	401 262 2304	MT-GLAZE 1.0K DC 1/16W
C1512	403 345 3802	TA-SOLID 22U M 4V	R1516	401 275 1905	MT-GLAZE 2K DC 1/16W
C1513	403 345 4205	TA-SOLID 47U M 6.3V	R1519	401 225 2006	MT-GLAZE 680 JA 1/16W
C1517	403 312 6805	CERAMIC 0.1U Z 16V	R1522	401 225 3805	MT-GLAZE 1.5K JA 1/16W
C1519	403 334 3806	CERAMIC 10U K 6.3V	R1523	401 105 5806	MT-GLAZE 56 JA 1/16W
C1531	403 312 6805	CERAMIC 0.1U Z 16V	R1526	401 262 2502	MT-GLAZE 68 DD 1/16W
C1601	403 345 4304	TA-SOLID 22U M 10V	R1527	401 226 1503	MT-GLAZE 0.000 ZA 1/16W
C1602	403 345 4205	TA-SOLID 47U M 6.3V	R1528	401 224 9303	MT-GLAZE 1K JA 1/16W
C1603	403 345 4304	TA-SOLID 22U M 10V	R1530	401 226 2401	MT-GLAZE 560 JA 1/16W
C1611	403 343 8700	CERAMIC 1U M 12V	R1531	401 226 2401	MT-GLAZE 560 JA 1/16W
C1612	403 334 3806	CERAMIC 10U K 6.3V	R1532	401 226 1503	MT-GLAZE 0.000 ZA 1/16W
C1613	403 343 8700	CERAMIC 1U M 12V	R1604	401 225 1207	MT-GLAZE 4.7K JA 1/16W
	(RESISTORS)		R1605	401 225 1207	MT-GLAZE 4.7K JA 1/16W
R1010	401 226 1503	MT-GLAZE 0.000 ZA 1/16W	R1607	401 224 9303	MT-GLAZE 1K JA 1/16W
R1011	401 225 7902	MT-GLAZE 220 JA 1/16W	R9501	401 225 1801	MT-GLAZE 47 JA 1/16W
R1013	401 225 7902	MT-GLAZE 220 JA 1/16W	R9502	401 226 2401	MT-GLAZE 560 JA 1/16W
			R9503	401 224 9303	MT-GLAZE 1K JA 1/16W

LOCATION	PARTS NO.	DESCRIPTION
	(SWITCH)	
S1001	645 023 0844	SWITCH,PUSH 1P-1TX1,
	(CONNECTORS)	
CN101	645 036 7489	SOCKET,PWB-PWB 40(N.S.P)
CN102	645 030 6655	SOCKET,PWB-PWB 50(N.S.P)
CN103	645 035 5387	PLUG,PWB-PWB 30P (N.S.P)
CN106	645 035 5400	PLUG,PWB-PWB 30P (N.S.P)
CN141	645 024 0706	SOCKET,CARD 22P (N.S.P)
CN951	645 006 4647	PLUG,2P (N.S.P)
	(MISCELLANEOUS)	
Y1001	411 174 1708	SCR S-TPG PAN PCS 1.7X3.5 (SMART-MEDIA)
Y1101	636 056 0826	SHIELD CASE-CA2,SIDE-B
Y1102	636 056 0963	SPACER CA2,SIDE-B SR662

COMPL PWB,PW-1

636 055 4290

(SEMICONDUCTORS)

Q5001	405 115 5207	TR 2SC4617 R
Q5002	405 148 3904	TR CPH3209
Q5003	405 092 1100	TR 2SA1577-P
OR	405 092 1209	TR 2SA1577-Q
OR	405 092 1407	TR 2SA1577-R
Q5004	405 092 1100	TR 2SA1577-P
OR	405 092 1209	TR 2SA1577-Q
OR	405 092 1407	TR 2SA1577-R
Q5005	405 092 1100	TR 2SA1577-P
OR	405 092 1209	TR 2SA1577-Q
OR	405 092 1407	TR 2SA1577-R
Q5007	405 148 3904	TR CPH3209
Q5008	405 148 3904	TR CPH3209
Q5009	405 148 7100	TR CPH6401
Q5010	405 115 5207	TR 2SC4617 R
Q5012	405 115 6907	TR DTC114EE
Q5013	405 129 2902	TR UMH11N
Q5014	405 115 6907	TR DTC114EE
Q5015	405 152 1408	TR 2SK2742
Q5016	405 129 2308	TR UMZ1N
Q5017	405 092 1100	TR 2SA1577-P
OR	405 092 1209	TR 2SA1577-Q
OR	405 092 1407	TR 2SA1577-R
Q5019	405 148 6905	TR CPH3303
Q5020	405 148 6905	TR CPH3303
Q5021	405 129 2308	TR UMZ1N
Q5022	405 115 6907	TR DTC114EE
Q5024	405 129 2308	TR UMZ1N
Q5025	405 129 2902	TR UMH11N
Q5026	405 129 2308	TR UMZ1N
Q5027	405 129 3008	TR UMD2N
Q5028	405 129 8409	TR UMC2N
Q5029	405 129 3008	TR UMD2N
Q5030	405 129 3008	TR UMD2N
Q5031	405 129 2308	TR UMZ1N
Q5032	405 129 3008	TR UMD2N
Q5033	405 130 1109	TR UMY1N
Q5401	405 115 7508	TR DTC123JE
Q5402	405 115 6907	TR DTC114EE
Q5405	405 150 6603	TR CPH3210
Q5406	405 150 5002	TR CPH3109
Q5407	405 115 5207	TR 2SC4617 R
Q5409	405 151 9504	TR CY20AAJ-8

(INTEGRATED CIRCUITS)

IC501	409 417 8300	IC LA5627W
IC503	409 301 5507	IC TC7S08FU

(DIODES)

D5001	407 203 5809	DIODE F02J9
D5002	407 203 5809	DIODE F02J9
D5003	407 201 2701	DIODE RB051L-40
D5006	407 203 5809	DIODE F02J9
D5007	407 201 2701	DIODE RB051L-40
D5008	407 205 5203	DIODE RB521S-30
D5009	407 205 5203	DIODE RB521S-30
D5010	407 201 2701	DIODE RB051L-40
D5011	407 162 8507	DIODE DAN222
D5012	407 162 8507	DIODE DAN222
D5013	407 203 5601	DIODE RB461F
D5014	407 203 5601	DIODE RB461F
D5015	407 203 5601	DIODE RB461F
D5402	407 202 0300	DIODE F1F16
D5403	407 122 2606	DIODE SFPM-64
D5404	407 202 0102	DIODE F1SN4
D5405	407 199 4503	DIODE CR08AS-8-T1

LOCATION	PARTS NO.	DESCRIPTION
D5407	407 151 4701	DIODE 1SS301-(TE85L)
OR	407 130 4401	DIODE DAN202U
OR	407 134 7408	DIODE MA141WK
OR	407 106 1601	DEODE DCG015
D5410	407 151 4701	DIODE 1SS301-(TE85L)
OR	407 130 4401	DIODE DAN202U
OR	407 134 7408	DIODE MA141WK
OR	407 106 1601	DEODE DCG015
	(VARIABLE RESISTORS)	
VR501	645 028 2249	VR,SEMI,3.3K S
VR502	645 028 2201	VR,SEMI,2.2K S
VR503	645 028 2201	VR,SEMI,2.2K S
VR504	645 019 5143	VR,SEMI,1K S
VR505	645 019 5143	VR,SEMI,1K S
VR506	645 019 5143	VR,SEMI,1K S
	(INDUCTORS)	
L5002	645 037 1530	INDUCTOR,47U K
L5003	645 037 1530	INDUCTOR,47U K
L5004	645 037 1530	INDUCTOR,47U K
L5005	645 037 0601	INDUCTOR,10U M
L5006	645 021 5315	INDUCTOR,110 OHM
L5007	645 030 5887	INDUCTOR,1000 OHM
L5008	645 037 1523	INDUCTOR,10U K
L5010	645 038 6701	INDUCTOR,4.7U M
L5011	645 037 1523	INDUCTOR,10U K
L5012	645 037 1523	INDUCTOR,10U K
L5013	645 037 1523	INDUCTOR,10U K
L5014	645 037 1523	INDUCTOR,10U K
L5015	645 037 1530	INDUCTOR,47U K
L5016	645 037 0601	INDUCTOR,10U M
L5017	645 036 7496	INDUCTOR,4.7U M
L5018	645 037 1530	INDUCTOR,47U K
L5401	645 037 0601	INDUCTOR,10U M
	(TRANSFORMERS)	
T5001	645 037 5040	TRANS,POWER,PULSE
T5002	645 023 1728	TRANS,POWER,PULSE
T5401	645 032 8831	TRANS,STEP UP
T5402	645 031 6951	TRANS,STEP UP
	(CAPACITORS)	
C5001	403 325 7608	CERAMIC 1U K 16V
C5002	403 325 7608	CERAMIC 1U K 16V
C5003	403 323 6009	CERAMIC 10U M 16V
C5004	403 333 3708	CERAMIC 10U M 10V
C5005	403 333 3708	CERAMIC 10U M 10V
C5006	403 311 4505	CERAMIC 1000P K 50V
C5007	403 314 7404	CERAMIC 3300P K 50V
C5008	403 340 3906	CERAMIC 1U M 6.3V
C5009	403 335 1405	CERAMIC 10U K 6.3V
C5010	403 325 7608	CERAMIC 1U K 16V
C5011	403 323 6009	CERAMIC 10U M 16V
C5012	403 325 7608	CERAMIC 1U K 16V
C5014	403 340 3906	CERAMIC 1U M 6.3V
C5015	403 338 4403	CERAMIC 0.1U K 16V
C5016	403 340 3906	CERAMIC 1U M 6.3V
C5017	403 319 3005	CERAMIC 220P J 25V
C5018	403 319 3005	CERAMIC 220P J 25V
C5021	403 345 3000	POS-SOLID 47U M 6.3V
C5022	403 345 3901	CERAMIC 3.3U M 6.3V
C5027	403 340 3906	CERAMIC 1U M 6.3V
C5029	403 335 1405	CERAMIC 10U K 6.3V
C5030	403 335 1405	CERAMIC 10U K 6.3V
C5031	403 340 3906	CERAMIC 1U M 6.3V
C5032	403 311 5403	CERAMIC 82P J 50V
C5033	403 311 7704	CERAMIC 4700P K 25V
C5038	403 311 4505	CERAMIC 1000P K 50V
C5039	403 319 3005	CERAMIC 220P J 25V
C5041	403 155 1807	CERAMIC 0.01U K 25V
C5042	403 155 1807	CERAMIC 0.01U K 25V
C5043	403 342 7506	CERAMIC 1000P J 50V
C5044	403 342 7506	CERAMIC 1000P J 50V
C5045	403 155 1807	CERAMIC 0.01U K 25V
C5046	403 340 3906	CERAMIC 1U M 6.3V
C5047	403 338 4403	CERAMIC 0.1U K 16V
C5048	403 155 1807	CERAMIC 0.01U K 25V
C5049	403 338 4403	CERAMIC 0.1U K 16V
C5050	403 155 1807	CERAMIC 0.01U K 25V
C5051	403 338 4403	CERAMIC 0.1U K 16V
C5052	403 335 4703	CERAMIC 0.22U K 6.3V
C5053	403 169 2807	CERAMIC 330P J 50V
C5054	403 340 3906	CERAMIC 1U M 6.3V
C5055	403 340 3906	CERAMIC 1U M 6.3V
C5056	403 311 4505	CERAMIC 1000P K 50V

LOCATION	PARTS NO.	DESCRIPTION	LOCATION	PARTS NO.	DESCRIPTION
C5058	403 345 3109	POS-SOLID 33U M 10V	R5074	401 258 9300	MT-GLAZE 220K DC 1/16W
C5059	403 345 3000	POS-SOLID 47U M 6.3V	R5075	401 258 0406	MT-GLAZE 120K DC 1/16W
C5061	403 335 1405	CERAMIC 10U K 6.3V	R5076	401 258 9300	MT-GLAZE 220K DC 1/16W
C5062	403 345 3000	POS-SOLID 47U M 6.3V	R5077	401 262 5206	MT-GLAZE 1.5K DC 1/16W
C5064	403 345 3901	CERAMIC 3.3U M 6.3V	R5078	401 224 9303	MT-GLAZE 1K JA 1/16W
C5065	403 340 3906	CERAMIC 1U M 6.3V	R5082	401 037 5202	MT-GLAZE 100 JA 1/10W
C5069	403 340 3906	CERAMIC 1U M 6.3V	R5083	401 235 1402	MT-GALZE 1.2K JA 1/16W
C5070	403 340 3906	CERAMIC 1U M 6.3V	R5084	401 225 1306	MT-GLAZE 470 JA 1/16W
C5401	403 345 3000	POS-SOLID 47U M 6.3V	R5086	401 226 1503	MT-GLAZE 0.000 ZA 1/16W
C5403	403 338 2904	CERAMIC 0.47U K 10V	R5087	401 226 1503	MT-GLAZE 0.000 ZA 1/16W
C5404	403 311 4505	CERAMIC 1000P K 50V	R5088	401 225 1405	MT-GLAZE 47K JA 1/16W
C5406	403 340 3906	CERAMIC 1U M 6.3V	R5089	401 226 1503	MT-GLAZE 0.000 ZA 1/16W
C5407	403 311 3409	CERAMIC 0.01U K 16V	R5090	401 226 1503	MT-GLAZE 0.000 ZA 1/16W
C5409	403 347 9109	CERAMIC 0.033U Z 16V	R5096	401 261 1508	MT-GLAZE 4.3K JA 1/16W
C5410	403 341 4407	CERAMIC 0.047U K 350V	R5097	401 224 9006	MT-GLAZE 10K JA 1/16W
C5411	403 330 5903	CERAMIC 0.01U K 500V	R5098	401 226 1503	MT-GLAZE 0.000 ZA 1/16W
C5412	404 081 1701	ELECT 60U K 330V	R5099	401 226 1503	MT-GLAZE 0.000 ZA 1/16W
C5414	403 311 7704	CERAMIC 4700P K 25V	R5401	401 224 9303	MT-GLAZE 1K JA 1/16W
(RESISTORS)			R5408	401 037 3406	MT-GLAZE 82 JA 1/8W
R5003	401 224 8900	MT-GLAZE 100K JA 1/16W	R5410	401 037 5202	MT-GLAZE 100 JA 1/10W
R5004	401 224 9501	MT-GLAZE 2.2K JA 1/16W	R5411	401 224 9006	MT-GLAZE 10K JA 1/16W
R5005	401 262 1000	MT-GLAZE 33K DC 1/16W	R5412	401 227 2400	MT-GLAZE 15 JA 1/16W
R5006	401 262 1703	MT-GLAZE 2.7K DC 1/16W	R5413	401 224 9006	MT-GLAZE 10K JA 1/16W
R5007	401 224 8900	MT-GLAZE 100K JA 1/16W	R5414	401 224 9303	MT-GLAZE 1K JA 1/16W
R5008	401 262 2304	MT-GLAZE 1.0K DC 1/16W	R5417	402 078 4407	MT-GLAZE 10M FKG 1/8W
R5009	401 224 9006	MT-GLAZE 10K JA 1/16W	R5418	401 226 5402	MT-GLAZE 56 JA 1/16W
R5010	401 224 8801	MT-GLAZE 100 JA 1/16W	R5419	401 262 1208	MT-GLAZE 82K DC 1/16W
R5011	401 225 1702	MT-GLAZE 39K JA 1/16W	R5422	402 079 0200	MT-GLAZE 220K JKG 1/8W
R5013	401 235 1402	MT-GALZE 1.2K JA 1/16W	R5423	401 225 0309	MT-GLAZE 33 JA 1/16W
R5014	401 261 1508	MT-GLAZE 4.3K JA 1/16W	R5424	401 226 5402	MT-GLAZE 56 JA 1/16W
R5015	401 224 9006	MT-GLAZE 10K JA 1/16W	R5425	402 077 7409	MT-GLAZE 100K JKG 1/8W
R5016	401 038 8400	MT-GLAZE 62 JA 1/10W	R5426	401 225 9005	MT-GLAZE 470K JA 1/16W
R5017	401 262 1000	MT-GLAZE 33K DC 1/16W	R5429	401 224 9006	MT-GLAZE 10K JA 1/16W
R5018	401 262 1703	MT-GLAZE 2.7K DC 1/16W	R5470	401 224 9303	MT-GLAZE 1K JA 1/16W
R5019	401 262 1307	MT-GLAZE 2.4K DC 1/16W	(PROTECTORS)		
R5020	401 275 2001	MT-GLAZE 30K DC 1/16W	PR501	△ 645 029 2408	PROTECTOR,IC 2A 24V
R5021	401 262 1000	MT-GLAZE 33K DC 1/16W	PR502	△ 645 029 2408	PROTECTOR,IC 2A 24V
R5022	401 263 1900	MT-GLAZE 3.3K DC 1/16W	PR503	△ 645 029 2378	PROTECTOR,IC 1.5A 32V
R5023	401 038 8400	MT-GLAZE 62 JA 1/10W	PR504	△ 645 029 2378	PROTECTOR,IC 1.5A 32V
R5024	401 224 9006	MT-GLAZE 10K JA 1/16W	PR505	△ 645 029 2378	PROTECTOR,IC 1.5A 32V
R5025	401 235 1402	MT-GALZE 1.2K JA 1/16W	(JACK)		
R5026	401 225 1405	MT-GLAZE 47K JA 1/16W	JK501	△ 645 027 7030	SOCKET,DC, DC JACK
R5027	401 225 1405	MT-GLAZE 47K JA 1/16W	(CONNECTORS)		
R5028	401 225 1405	MT-GLAZE 47K JA 1/16W	CN501	645 005 6932	PLUG,SIDE-ZR-SM3 (N.S.P)
R5029	401 224 8900	MT-GLAZE 100K JA 1/16W	CN502	645 009 9892	SOCKET,PWB-PWB 30(N.S.P)
R5030	401 262 0706	MT-GLAZE 39K DC 1/16W	CN503	636 055 8939	ASSY,WIRE BAT&PW1-SR662 (N.S.P.)
R5031	401 225 2105	MT-GLAZE 12K JA 1/16W	<hr/>		
R5032	401 226 2401	MT-GLAZE 560 JA 1/16W	COMPL PWB,TB-1		
R5033	401 224 9501	MT-GLAZE 2.2K JA 1/16W	636 055 4306		
R5034	401 224 8900	MT-GLAZE 100K JA 1/16W	(SWITCH)		
R5035	401 261 1508	MT-GLAZE 4.3K JA 1/16W	S6001	645 032 8442	SWITCH,FT,
R5036	401 225 8701	MT-GLAZE 120K JA 1/16W	<hr/>		
R5039	401 235 1402	MT-GALZE 1.2K JA 1/16W	COMPL PWB,TB-2		
R5040	401 224 9006	MT-GLAZE 10K JA 1/16W	636 055 4313		
R5041	401 037 9101	MT-GLAZE 180 JA 1/10W	(SWITCH)		
R5042	401 262 1000	MT-GLAZE 33K DC 1/16W	S6002	645 032 8442	SWITCH,FT,
R5043	401 269 3908	MT-GLAZE 4.7K DC 1/16W	<hr/>		
R5044	401 224 8900	MT-GLAZE 100K JA 1/16W	COMPL PWB,SY-1		
R5045	401 224 8900	MT-GLAZE 100K JA 1/16W	636 055 4283		
R5048	401 224 9501	MT-GLAZE 2.2K JA 1/16W	(SEMICONDUCTORS)		
R5049	401 224 8900	MT-GLAZE 100K JA 1/16W	Q3001	405 078 6105	TR 2SA1677
R5050	401 224 8900	MT-GLAZE 100K JA 1/16W	OR	405 096 1205	TR DTA124EU
R5051	401 224 9501	MT-GLAZE 2.2K JA 1/16W	OR	405 119 1007	TR UN5112
R5052	401 225 0705	MT-GLAZE 56K JA 1/16W	Q3002	405 078 6105	TR 2SA1677
R5054	401 224 9303	MT-GLAZE 1K JA 1/16W	OR	405 096 1205	TR DTA124EU
R5057	401 224 9303	MT-GLAZE 1K JA 1/16W	OR	405 119 1007	TR UN5112
R5058	401 261 1508	MT-GLAZE 4.3K JA 1/16W	Q3003	405 115 7201	TR DTC144EE
R5059	401 037 5400	MT-GLAZE 1K JA 1/10W	Q3071	405 129 2209	TR UMX1N
R5060	401 224 8900	MT-GLAZE 100K JA 1/16W	OR	405 106 4707	TR XP4501
R5061	401 274 9704	MT-GLAZE 24K DC 1/16W	Q3072	405 129 2209	TR UMX1N
R5062	401 224 9402	MT-GLAZE 1.0M JA 1/16W	OR	405 106 4707	TR XP4501
R5063	401 224 9402	MT-GLAZE 1.0M JA 1/16W	(INTEGRATED CIRCUITS)		
R5064	401 263 1702	MT-GLAZE 1.2K DC 1/16W	IC301	410 356 1307	IC UPD78062GC-A19-8EU
R5065	401 258 9102	MT-GLAZE 5.6K DC 1/16W	IC302	409 383 1008	S-8423NFS
R5066	401 258 9300	MT-GLAZE 220K DC 1/16W	IC312	409 432 2505	IC LMV321M7X
R5067	401 258 0406	MT-GLAZE 120K DC 1/16W	(DIODES)		
R5068	401 224 9402	MT-GLAZE 1.0M JA 1/16W	D3033	407 130 2605	DIODE MA143A
R5069	401 262 2304	MT-GLAZE 1.0K DC 1/16W	OR	407 120 4503	DIODE DA204U-T106
R5070	401 258 0406	MT-GLAZE 120K DC 1/16W	<hr/>		
R5071	401 258 9300	MT-GLAZE 220K DC 1/16W			
R5072	401 224 9402	MT-GLAZE 1.0M JA 1/16W			
R5073	401 258 0406	MT-GLAZE 120K DC 1/16W			

LOCATION	PARTS NO.	DESCRIPTION
D3041	407 199 1809	LED SML-020MLT, VF LED
D3042	407 187 6304	LED SML-110VT, SELF TIMER LED
D3051	407 149 0807	DIODE 1SS355
D3052	407 165 4001	DIODE DA227
D3054	407 149 0807	DIODE 1SS355
D3055	407 149 0807	DIODE 1SS355
D3062	407 188 9809	DIODE MA742
D3064	407 165 4001	DIODE DA227
D3065	407 149 0807	DIODE 1SS355
D3066	407 165 4001	DIODE DA227
D3067	407 165 4001	DIODE DA227
D3069	407 149 0807	DIODE 1SS355
D3070	407 149 0807	DIODE 1SS355
(CRYSTAL DEVICES)		
X3001	645 037 5156	OSC,CERAMIC 4.00MHZ
X3002	645 034 7993	OSC,CRYSTAL 32.768KHZ
(CAPACITORS)		
C3001	403 311 7506	CERAMIC 22P J 50V
C3002	403 311 7506	CERAMIC 22P J 50V
C3003	403 346 2309	CERAMIC 0.1U K 10V
C3004	403 311 4505	CERAMIC 1000P K 50V
C3005	403 311 3409	CERAMIC 0.01U K 16V
C3006	403 346 2309	CERAMIC 0.1U K 10V
C3009	403 346 2309	CERAMIC 0.1U K 10V
C3051	403 274 0903	TA-SOLID 22U M 6.3V
C3053	403 346 2309	CERAMIC 0.1U K 10V
C3054	403 340 3906	CERAMIC 1U M 6.3V
C3055	403 346 2309	CERAMIC 0.1U K 10V
C3056	403 346 2309	CERAMIC 0.1U K 10V
C3057	403 334 4902	DL-ELECT 0.1F Z 5.5V
C3058	403 340 3906	CERAMIC 1U M 6.3V
C3101	403 073 4409	CERAMIC 0.039U K 50V
C3102	403 335 1405	CERAMIC 10U K 6.3V
C3103	403 311 3409	CERAMIC 0.01U K 16V
C3104	403 311 3409	CERAMIC 0.01U K 16V
C3106	403 340 3906	CERAMIC 1U M 6.3V
C3121	403 335 1405	CERAMIC 10U K 6.3V
C3123	403 340 3906	CERAMIC 1U M 6.3V
C3124	403 340 3906	CERAMIC 1U M 6.3V
C3125	403 340 3906	CERAMIC 1U M 6.3V
C3127	403 340 3906	CERAMIC 1U M 6.3V
C3128	403 340 3906	CERAMIC 1U M 6.3V
C3129	403 335 1405	CERAMIC 10U K 6.3V
(RESISTORS)		
R3001	401 224 9006	MT-GLAZE 10K JA 1/16W
R3002	401 225 1405	MT-GLAZE 47K JA 1/16W
R3003	401 224 9006	MT-GLAZE 10K JA 1/16W
R3004	401 225 0408	MT-GLAZE 330K JA 1/16W
R3005	401 225 1405	MT-GLAZE 47K JA 1/16W
R3006	401 225 1405	MT-GLAZE 47K JA 1/16W
R3010	401 225 1405	MT-GLAZE 47K JA 1/16W
R3011	401 257 4108	MT-GLAZE 100K DC 1/16W
R3012	401 257 4108	MT-GLAZE 100K DC 1/16W
R3014	401 224 8900	MT-GLAZE 100K JA 1/16W
R3015	401 225 1405	MT-GLAZE 47K JA 1/16W
R3016	401 224 9006	MT-GLAZE 10K JA 1/16W
R3017	401 224 8900	MT-GLAZE 100K JA 1/16W
R3018	401 224 9303	MT-GLAZE 1K JA 1/16W
R3021	401 224 9006	MT-GLAZE 10K JA 1/16W
R3022	401 224 9907	MT-GLAZE 22K JA 1/16W
R3023	401 224 9006	MT-GLAZE 10K JA 1/16W
R3024	401 224 9006	MT-GLAZE 10K JA 1/16W
R3025	401 224 9907	MT-GLAZE 22K JA 1/16W
R3041	401 225 1306	MT-GLAZE 470 JA 1/16W
R3042	401 225 0002	MT-GLAZE 270 JA 1/16W
R3043	401 225 7902	MT-GLAZE 220 JA 1/16W
R3051	401 224 8900	MT-GLAZE 100K JA 1/16W
R3052	401 224 8900	MT-GLAZE 100K JA 1/16W
R3053	401 224 9303	MT-GLAZE 1K JA 1/16W
R3056	401 224 9303	MT-GLAZE 1K JA 1/16W
R3101	401 224 9501	MT-GLAZE 2.2K JA 1/16W
R3102	401 224 9501	MT-GLAZE 2.2K JA 1/16W
R3103	401 224 9006	MT-GLAZE 10K JA 1/16W
R3104	401 224 8801	MT-GLAZE 100 JA 1/16W

LOCATION	PARTS NO.	DESCRIPTION
R3105	401 225 1207	MT-GLAZE 4.7K JA 1/16W
R3106	401 224 9303	MT-GLAZE 1K JA 1/16W
R3107	401 225 0101	MT-GLAZE 27K JA 1/16W
R3108	401 224 9501	MT-GLAZE 2.2K JA 1/16W
R3109	401 224 8900	MT-GLAZE 100K JA 1/16W
R3120	401 226 1503	MT-GLAZE 0.000 ZA 1/16W
R3161	401 237 8508	MT-GLAZE 390K JA 1/16W
R3162	401 225 1405	MT-GLAZE 47K JA 1/16W
R3163	401 224 9303	MT-GLAZE 1K JA 1/16W
R3164	401 224 9006	MT-GLAZE 10K JA 1/16W
R3166	401 224 9303	MT-GLAZE 1K JA 1/16W
R3167	401 224 9303	MT-GLAZE 1K JA 1/16W
R3168	401 225 0408	MT-GLAZE 330K JA 1/16W
(SWITCHES)		
S3001	645 029 5911	SWITCH,SLIDE 1P-3T,
S3029	645 028 4069	SWITCH,PUSH 1P-2TX1, SHUTTER
(CONNECTORS)		
CN301	645 035 5424	SOCKET,PWB-PWB 30(N.S.P)
CN302	645 025 1320	PLUG,2P (N.S.P)
CN303	645 002 6423	SOCKET,FFC 5P (N.S.P)
CN304	645 025 1320	PLUG,2P (N.S.P)
CN310	645 002 2876	PLUG,2P (N.S.P)

ACCESSORIES

△	645 037 0328	BATTERY CHAGER,VPC-X360 ONLY
△	645 037 0342	BATTERY CHAGER,EXCEPT VPC-X360
△	645 037 0205	BATTERY,RECHARGE,COMP. (NI-MH BATTERY)
	645 024 7330	CABLE,A/V
	645 017 7200	CABLE,MINI 8P&D-SUB 9P(MAC ADAPTER)
	645 020 3718	CABLE,MINI 8P&D-SUB 9P(MAC ADAPTER)
	645 020 3725	CABLE,MINI 8P&D-SUB 9P(MAC ADAPTER)
	645 020 7129	CABLE,MINI 8P&D-SUB 9P(MAC ADAPTER)
	645 023 3227	CABLE,PC DOS/V
	645 025 5403	CABLE,PC DOS/V
	645 024 6012	CABLE,SCART ADAPTOR,VPC-X360E ONLY
	636 056 2240	CASE SOFT-SR662/E
△	645 036 4129	CORD,POWER-1.2MK,VPC-X360EX ONLY
△	645 036 7434	CORD,POWER-1.2MK,VPC-X360E ONLY
△	645 036 4112	CORD,POWER-1.9MK,VPC-X360 ONLY
	645 037 9796	DISC,CD-ROM CELIS 662 WM
	645 036 9919	DISC,CD-ROM MGI PS8
	636 056 1007	STRAP HAND-SR662/J
	645 026 5297	UNIT,SSFDC
9112	636 056 1397	INSTRUCTION MANUAL(CAMERA: English), VPC-X360E ONLY
9112	636 056 1434	INSTRUCTION MANUAL(CAMERA: English, Spanish,French), EXCEPT VPC-X360E
9214	636 056 1458	INSTRUCTION MANUAL(CAMERA: German), VPC-X360EX ONLY
9113	636 055 5303	INSTRUCTION MANUAL(MGI PhotoSuite: English, Spanish, French, German)
9117	636 056 1410	INSTRUCTION MANUAL(SANYO Software Pack: English)
9213	636 057 0825	INSTRUCTION MANUAL(PDF SANYO Software Pack: English, Spanjsh, French, German)

PACKING MATERIALS

636 056 2127	CARTON CASE INNER-662/E,VPC-X360E ONLY
636 056 2134	CARTON CASE INNER-662/EX, VPC-X360EX ONLY
636 056 2141	CARTON CASE INNER-662/U,VPC-X360 ONLY
645 031 3080	POLY SHEET-0300X0300*NC
636 056 2189	REINFORCEMENT PAD,A-662/E(BOTTOM)
636 055 4627	REINFORCEMENT PAD,B-112/E (TOP)

SANYO Electric Co.,Ltd.
Osaka, Japan

OVERALL WIRING

